

FKC SERIES FLAT PANEL SOLAR COLLECTORS

IN ROOF MOUNTING FOR WORCESTER SOLAR HEATING SYSTEMS

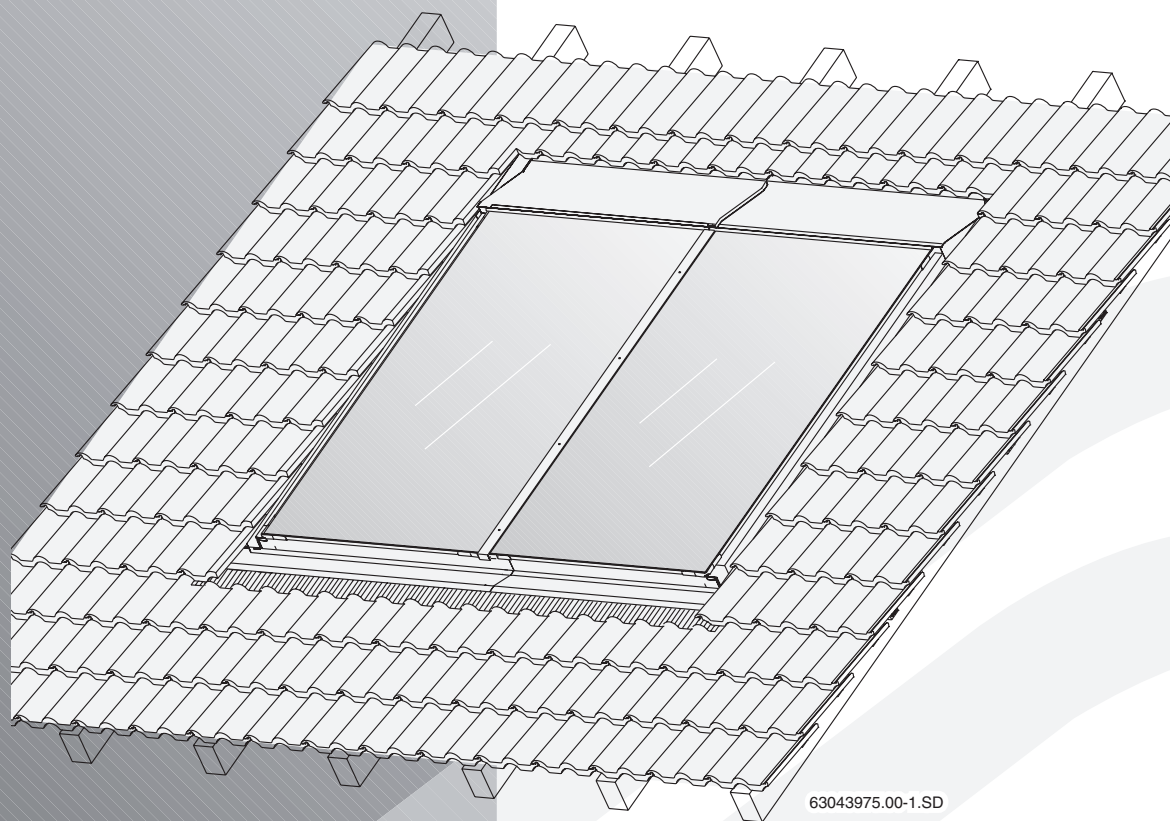

63043975.00-1.SD

GB

Installation instructions

About this manual

This installation manual contains important information for the safe and appropriate installation of the roof mounted solar panels.

Notes are included with important information for situations in which there is no danger for persons or equipment.

These technical documents should be retained in a safe place. These may also be inspected at the manufacturer's premises.

The activities described in the installation manual assume expertise based on completed vocational training in gas or water-related installation. Only carry out these installation steps, if you possess these skills.

- ▶ Hand these installation instructions to the customer.
- ▶ Explain to the customer the function and operation of the related devices.

1	General information	4
2	Specifications	5
3	Safety	6
3.1	Correct use	6
3.2	Notes structure	7
3.3	Please observe these safety instructions	8
4	Before installation	9
4.1	General notes	9
4.2	Component description	10
4.3	Other equipment	12
4.4	Transport and storage	12
4.5	Technical documentation	13
4.6	Determining space required on roof	14
5	Roof preparations	15
5.1	Determining the initial installation positions	16
5.2	Fitting additional roof battens	17
6	Collector installation	21
6.1	Preparing to install the collectors	22
6.2	Fastening the collectors	25
7	Collector sensor connection	28
8	Header connection	29
8.1	Venting through pressure filling	29
8.2	De-airing through air vent (accessory) at highest point in the system	30
9	Fitting the connection set for two rows (accessory)	32
10	Installing the facing panels	33
10.1	Lower facing panels	34
10.2	Side facing panels	36
10.3	Middle cover strip between two collectors	36
10.4	Middle facing panel (when more than one row is being installed)	37
10.5	Side facing panels on the upper row (if installing more than one row)	38
10.6	Upper facing panels	38
10.7	Covering the roof	40
11	Final activities	41
11.1	Checking the installation	41
11.2	Insulating the connection and header pipes	41
12	Quick reference guide for two collectors	42

1 General information

This chapter details which technical rules and regulations apply to this installation.



USER NOTE

Observe all standards and guidelines applicable to the installation and operation of this system in your country.

UK		
Installation work on roofs	Connection of thermal solar heating systems	Installation and equipment of DHW cylinders
The Health and Safety at Work etc Act 1974	EN 12976: Thermal solar heating system and their components (pre-fabricated systems).	BS5546: 2000 Specification for installation of hot water supplies for domestic purposes, using gas-fired appliances of rated input not exceeding 70 kW.
The Management of Health and Safety at Work Regulations 1999	ENV 12977: Thermal solar heating system and their components (bespoke systems).	BS6700:1997 Specification for design, installation, testing and maintenance, of servicing supplying water for domestic use within buildings and their curtilages.
The Construction (Health Safety and Welfare) Regulations 1996	BS 6795: Code of practice for solar heating systems for swimming pools.	
The Construction (Design and Management) Regulations 1994		
The Lifting Operations and Lifting Equipment Regulations 1998		

Tab. 1 Technical rules for the installation of thermal solar heating systems (selection) in UK

Lightning protection

If the building height (installation height) exceeds 20 m, and there is no lightning conductor installed, ask your local electrical contractor to connect the components on the roof which conduct electricity with an electrical earth cable of at least 16 mm² to the earth bonding.

Special measures regarding lightning protection are not required for building heights (installation heights) of less than 20 m.



Where there is a lightning conductor system installed, ask your local electrical contractor to check the inclusion of the solar heating system into the lightning protection system.



USER NOTE

The installation of the Worcester Solar System must be carried out in accordance with the relevant requirements for safety, current IEE wiring regulations, local building regulations, building standards (Scotland) (Consolidation) regulations and by-laws of the local water company and health and safety document No 635 (Electricity at Work Regulations 1989).
BS 6795: Latest version

2 Specifications

FKC SERIES SOLAR PANELS		
Certificates		  
Length		2070 mm
Width		1145 mm
Height		90 mm
Clearance between collectors		25 mm
Fluid content, portrait version	V_f	0.86 l
Fluid content, landscape version	V_f	1.25 l
Gross absorber surface area	A_G	2.37 m ²
Net absorber surface area		2.23 m ²
Net weight, portrait version	m	41 kg
Net weight, landscape version	m	42 kg
Permissible operating pressure of the collector	p_{max}	6 bar

Tab. 2 Specifications

3 Safety

This chapter details how the notes for the installation instructions, as well as the general safety instructions, necessary for safe and trouble-free operation, are arranged in this manual.

The safety and user notes, which specifically refer to the installation, in the installation manual immediately following the individual installation steps, are found here.

Carefully read the safety instructions before commencing the installation.

Severe injury and even death, as well as material losses and environmental damage, may follow if you ignore safety instructions.

3.1 Correct use

This installation set holds the thermal solar collectors (portrait and landscape), which are installed on sloping roofs with a slope of 25° to 65°.

Operating conditions

Only erect the installation set on roofs whose construction can support the weight. If necessary, consult a structural engineer or a roofer.

The installation set is suitable for a max. standard snow load of 3.8 kN/m² and an installation height of max. 20 m.

3.2 Notes structure

Two levels are identified by signal terms:



RISK TO LIFE

Identifies possible dangers which might lead to serious injury or death if appropriate care is not taken.



RISK OF INJURY / SYSTEM DAMAGE

Identifies potentially dangerous situations, which might lead to mild or slight injuries or to material losses.

Further symbols identifying dangers and user notes:



RISK TO LIFE

from electric shock.



USER NOTE

Tip for the optimum utilisation and setting of the products plus other useful information.

3.3 Please observe these safety instructions



RISK TO LIFE

through a fall or falling parts.

WARNING!

- ▶ Ensure you have the correct safety equipment for working on roofs.
- ▶ Take appropriate action to prevent accidents when working on roofs.
- ▶ Whilst working on the roof, take all necessary precautions against a possible fall.
- ▶ Always wear your personal protective clothing and safety equipment.
- ▶ After completing the installation, always check the secure positioning of the installed set and that of the collectors.



RISK OF INJURY

Injury and operating faults can result from making changes to the system construction.

CAUTION!

- ▶ Never change the system construction.



RISK OF INJURY

Some parts may cause burns, if the collector and installation materials are exposed to solar radiation for longer periods of time.

CAUTION!

- ▶ Always wear your personal protective clothing and safety equipment.
- ▶ Cover the collector (e.g. with a sheet – available as an accessory 7739 300 399) and the installation material during the installation as protection against high temperatures resulting from solar irradiation.

4 Before installation

4.1 General notes



USER NOTE

It is recommended that the services of a roofing company, who are experienced in working on roofs and will be fully aware of the risks of working at height are considered.

Make yourself familiar with the on-site conditions and local regulations before commencing the installation.



CAUTION!

RISK OF INJURY

If the collector and its installation material are left exposed to the sunlight for a long period, the parts will become hot and may cause burns.

- ▶ Wear protective clothing.
- ▶ Cover the collector (e.g. with a covering sheet – available as an accessory 7739 300 399) and the installation material during the installation as protection against high temperatures resulting from solar irradiation.

Check

- the delivery for completeness and perfect condition.
- the optimum arrangement of the solar collectors. Take account of the direction of the sunlight (angle of inclination, southerly direction). Avoid the shade of high trees or structures and match the collector array to the shape of the building (e.g. aligned with windows, doors, etc.).



USER NOTE

Only use OEM components and replace any faulty parts immediately.



USER NOTE

Remove broken tiles, shingles or plates in the area of the collectors and replace them.

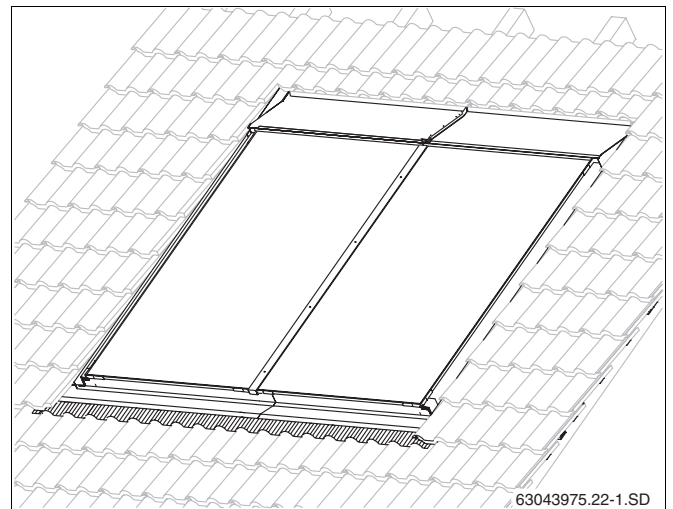

Fig. 1 General overview of collector pair – flush roof mounting

4.2 Component description

4.2.1 Installation set for the collectors

The installation sets are for fixing the collectors in place and sealing them.

The lower facing panels (Fig. 2, **Item 6, 9 and 10**) are designed for slate/shingle roofs with no flashing.

If installing more than one row of collectors, basic and extended installation sets are delivered separately.

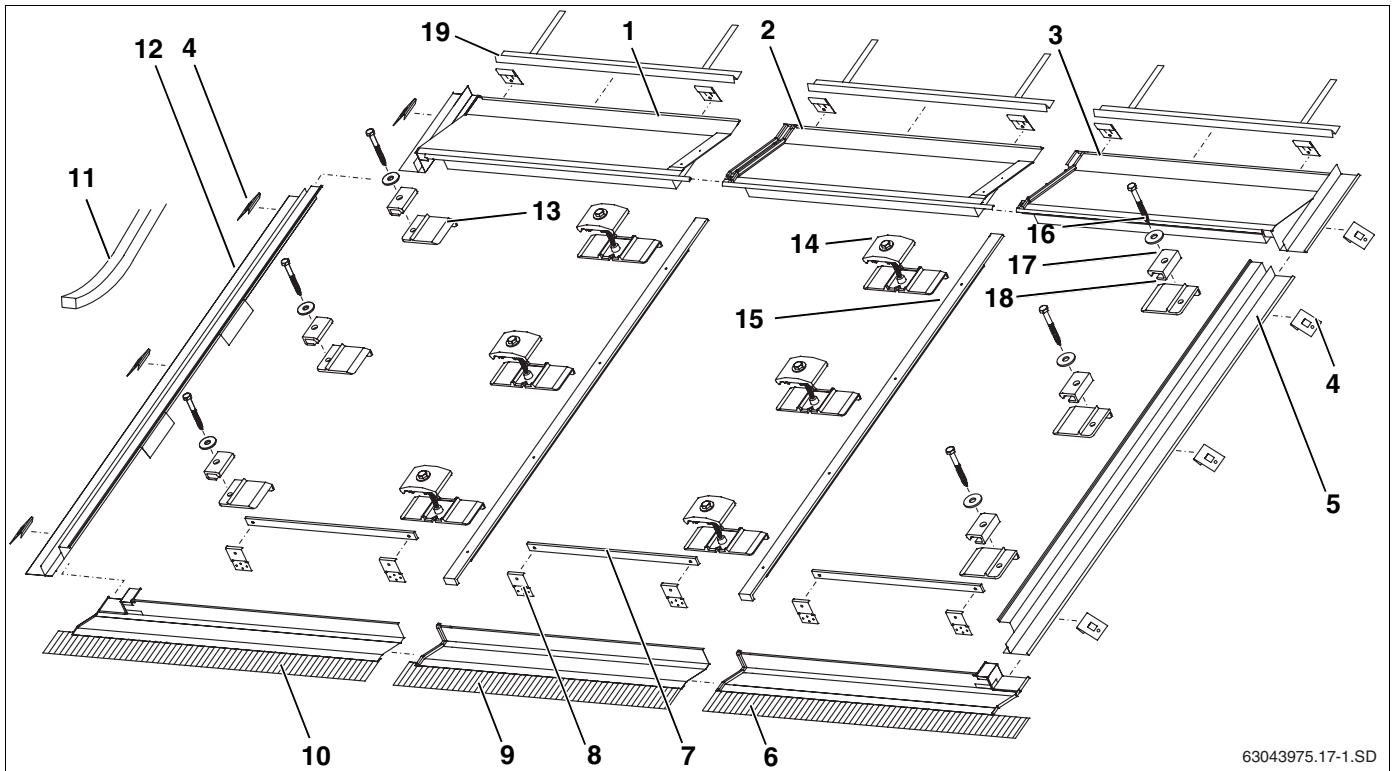

Fig. 2 1 basic set for the outer collectors and 1 extended set for the middle collector (portrait, single row)

Basic installation set for both outer collectors in one row (Fig. 2):

Item 1:	Upper left-hand facing panel	1 x
Item 3:	Upper right-hand facing panel	1 x
Item 4:	Clips	12 x
Item 5:	Side facing panel, right	1 x
Item 6:	Lower facing panel, right	1 x
Item 7:	Anti-slip protection bar	2 x
Item 8:	Anti-slip protection (x 6 for landscape collectors)	4 x
Item 10:	Lower facing panel, left	1 x
Item 11:	Roll of sealing tape	1 x
Item 12:	Side facing panel, left	1 x
Item 13:	Underlay plate, left	3 x
Item 14:	Double-sided clamp	3 x
Item 15:	Cover strip	1 x
Item 16:	Screw 6x40 with washer	6 x
Item 17:	Single-sided clamp	6 x
Item 18:	Underlay plate, right	3 x
Item 19:	Pan tile overlay	2 x

Extended installation set for each additional collector (Fig. 2):

Item 2:	Upper middle facing panel	1 x
Item 4:	Clips (4 spares)	6 x
Item 7:	Anti-slip protection bar	1 x
Item 8:	Anti-slip protection (x 3 for landscape collectors)	2 x
Item 9:	Lower facing panel, middle	1 x
Item 11:	Roll of sealing tape	1 x
Item 14:	Double-sided clamp	3 x
Item 15:	Cover strip	1 x
Item 19:	Pan tile overlay	1 x

4.2.2 Hydraulic connection

For hydraulic connections, a connection kit and a connection set between the collectors will be required.

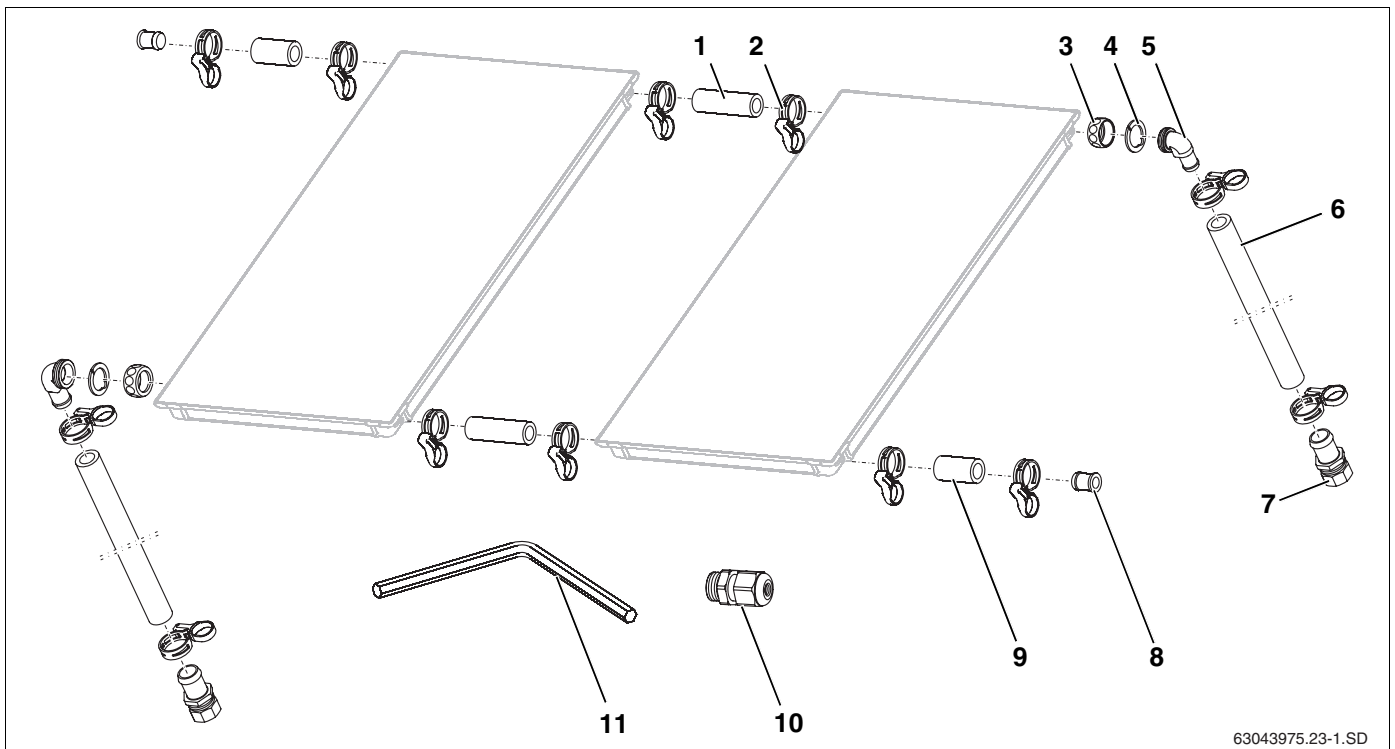

Fig. 3 Connection kit and connection set (illustration shows 2 portrait collectors)

Connection kit, per collector array (Fig. 3)

Item 2: Hose clip (1 x spare)	5 x	Item 7: Hose nozzle R $\frac{3}{4}$ with 22 mm compression fitting	2 x
Item 3: Nut	2 x	Item 8: Dummy plug	2 x
Item 4: Clamping disc	2 x	Item 9: Solar hose 55 mm	2 x
Item 5: Angled nozzle	2 x	Item 10: Fitting for collector sensor	1 x
Item 6: Solar hose 1000 mm	2 x	Item 11: Size 5 Allen Key	1 x

Connection set between the collectors, for each collector (in two corner protectors, Fig. 4)

Item 1: Solar hose 95 mm	2 x
Item 2: Hose clip	4 x

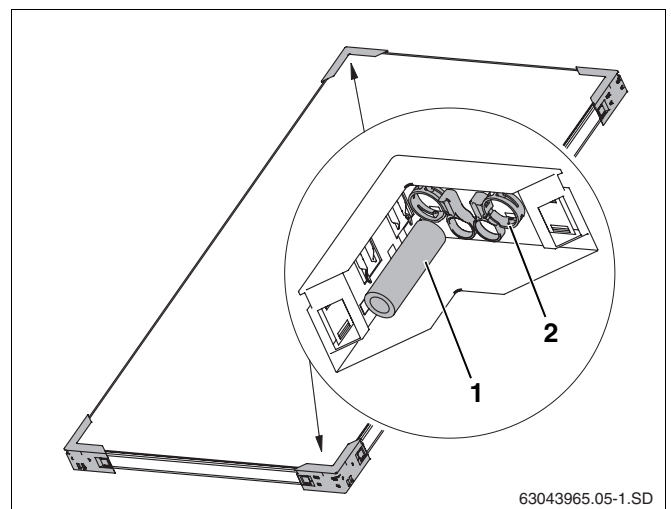

Fig. 4 Two corner protectors with one connection set

4.3 Other equipment

- Spirit level
- Plumb line
- Filling pump
- Vest harness with safety rope
- Pipe insulation
- Scaffolding
- Roofing ladder
- Crane or mobile hoist
- Cordless screwdriver and drill (Ø4 mm)
- Size 10 and 8 spanners (incl. 80 mm extension)

4.4 Transport and storage

Please ensure that the corner protectors are retained. They contain pipework connection pieces which are required for installation. All components are protected by transport packaging.



USER NOTE

Dispose of the transport packaging in an environmentally friendly recycling system.

Transport protection for collector connections

The collector connections are protected against damage by plastic caps.



SYSTEM DAMAGE

through damaged sealing faces.

CAUTION!

- ▶ Do not remove the plastic caps (Fig. 5, **Item 1**) until immediately prior to installation.

Storage

The collectors must be stored in dry conditions.



USER NOTE

Do not store collectors outside without protection from the rain.

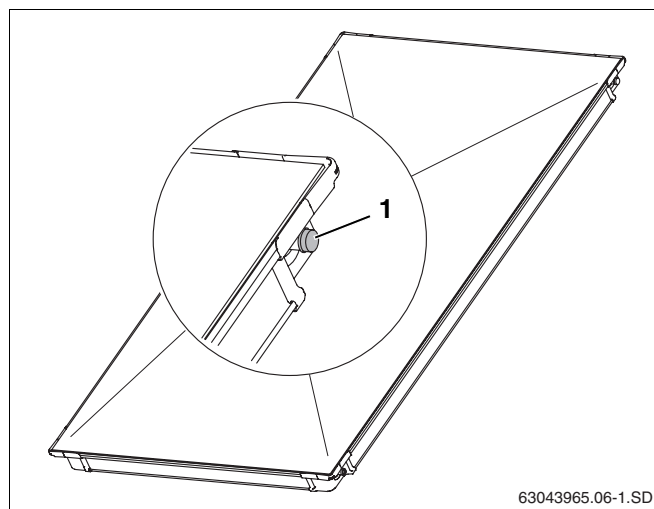

Fig. 5 Plastic caps on collector connections

63043965.06-1.SD

4.5 Technical documentation

The solar heating system consists of various components (Fig. 6). Installation, operation and maintenance documentation is provided for each component. Accessories may be accompanied by a separate document.

- Item 1:** Collector: instructions for flush roof mounting are enclosed with the connection kit
- Item 2:** Complete station: instructions enclosed with the complete station
- Item 3:** DHW cylinder: instructions enclosed with the DHW cylinder.
- Item 4:** DHW Cylinder: instructions enclosed with the DHW cylinder.

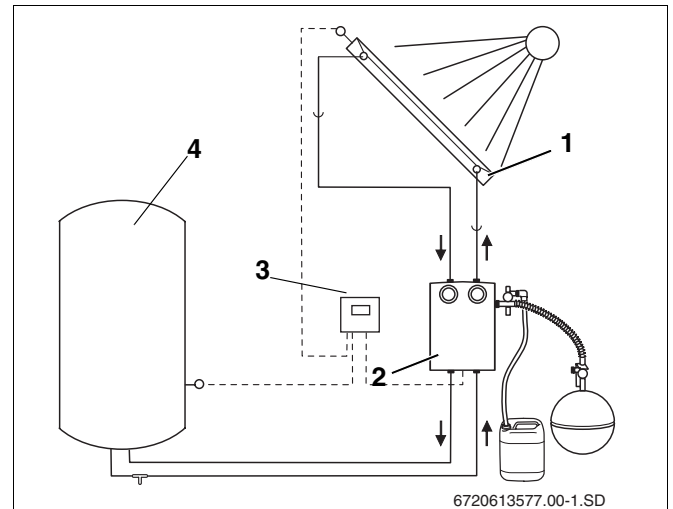

Fig. 6 Solar heating system components and technical documentation

4.6 Determining space required on roof

Please note the following minimum space requirements.

Dimension A and B

Area required for the collector array, incl. facing panels.

Dimension C

At least two tiles to the roof or chimney. Otherwise there is a risk of damaging the tiles, particularly if the tiles are laid in mortar.

Dimension D

Roof overhang including gable wall thickness.

Dimension E

Minimum 30 cm for fitting the connection cables in the attic.

Dimension F

Minimum 40 cm for fitting the connection cables in the attic.

Please note that the air vent must be the highest point of the system.

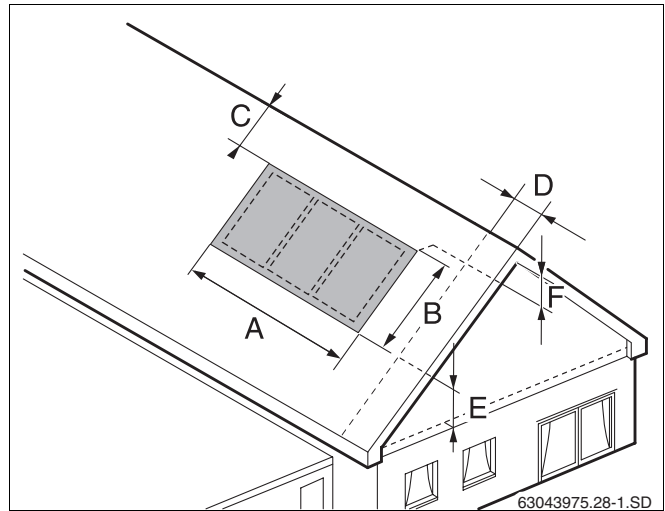

Fig. 7 Clearances to be observed

Space requirements for portrait collectors:

Number of collectors	Dimension A	Dim. B
2	2.67 m	2.80 m
3	3.84 m	2.80 m
4	5.01 m	2.80 m
5	6.18 m	2.80 m
6	7.41 m	2.80 m
7	8.52 m	2.80 m
8	9.69 m	2.80 m
9	10.86 m	2.80 m
10	12.03 m	2.80 m

Tab. 3 Space requirement for portrait installed collectors (incl. facing panels all around)

Space requirements for landscape collectors:

Number of collectors	Dimension A	Dim. B
2	4.52 m	1.87 m
3	6.61 m	1.87 m
4	8.71 m	1.87 m
5	10.80 m	1.87 m
6	12.90 m	1.87 m
7	14.99 m	1.87 m
8	17.09 m	1.87 m
9	18.96 m	1.87 m
10	21.28 m	1.87 m

Tab. 4 Space requirement for landscape installed collectors (incl. facing panels all around)

5 Roof preparations



WARNING!

RISK TO LIFE

Whilst working on the roof, take all necessary precautions against a possible fall.



WARNING!

RISK OF INJURY

through a fall or falling parts.

- ▶ Take appropriate action to prevent accidents when working on roofs.
- ▶ Always wear personal protective clothing and safety equipment.

5.1 Determining the initial installation positions

Before installation, carefully determine the initial positions.

Initial landscape position

- ▶ Determine dim. X (distance between the tiles that lie on the side facing panels, Fig. 8, **Pos. 1**) on the roof and mark it on the roof.



USER NOTE

If possible, plan in such a way that the tiles are only cut on the right side of the collector array, but always in a tile trough. After cutting, at least half of the tile should still remain.

Original portrait position

- ▶ Determine the lowest row of tiles (Fig. 8, **Item 2** taking dimension B into account (Fig. 8).



USER NOTE

If pan tiles need to be shortened, only cut the upper pan tiles.

Number Collectors	Dimension A		Dimension X	
	portrait	landscape	portrait	landscape
1	1.50 m	2.42 m	1.32 m	2.24 m
2	2.67 m	4.52 m	2.49 m	4.34 m
3	3.84 m	6.61 m	3.66 m	6.43 m
4	5.01 m	8.71 m	4.83 m	8.53 m
5	6.18 m	10.80 m	6.00 m	10.62 m
6	7.41 m	12.90 m	7.23 m	12.72 m
7	8.52 m	14.99 m	8.34 m	14.81 m
8	9.69 m	17.09 m	9.51 m	16.91 m
9	10.86 m	18.96 m	10.68 m	18.78 m
10	12.03 m	21.28 m	11.85 m	21.10 m

Tab. 5 Width of collector array, incl. facing panels (dim. A) and distance between the tiles (dim. X)

Number of rows	Dim. B	
	portrait	landscape
1	2.80 m	1.87 m
2	5.02 m	3.17 m
3	7.25 m	4.47 m
4	9.47 m	5.77 m

Tab. 6 Height of collector array, incl. facing panel (dim. B)

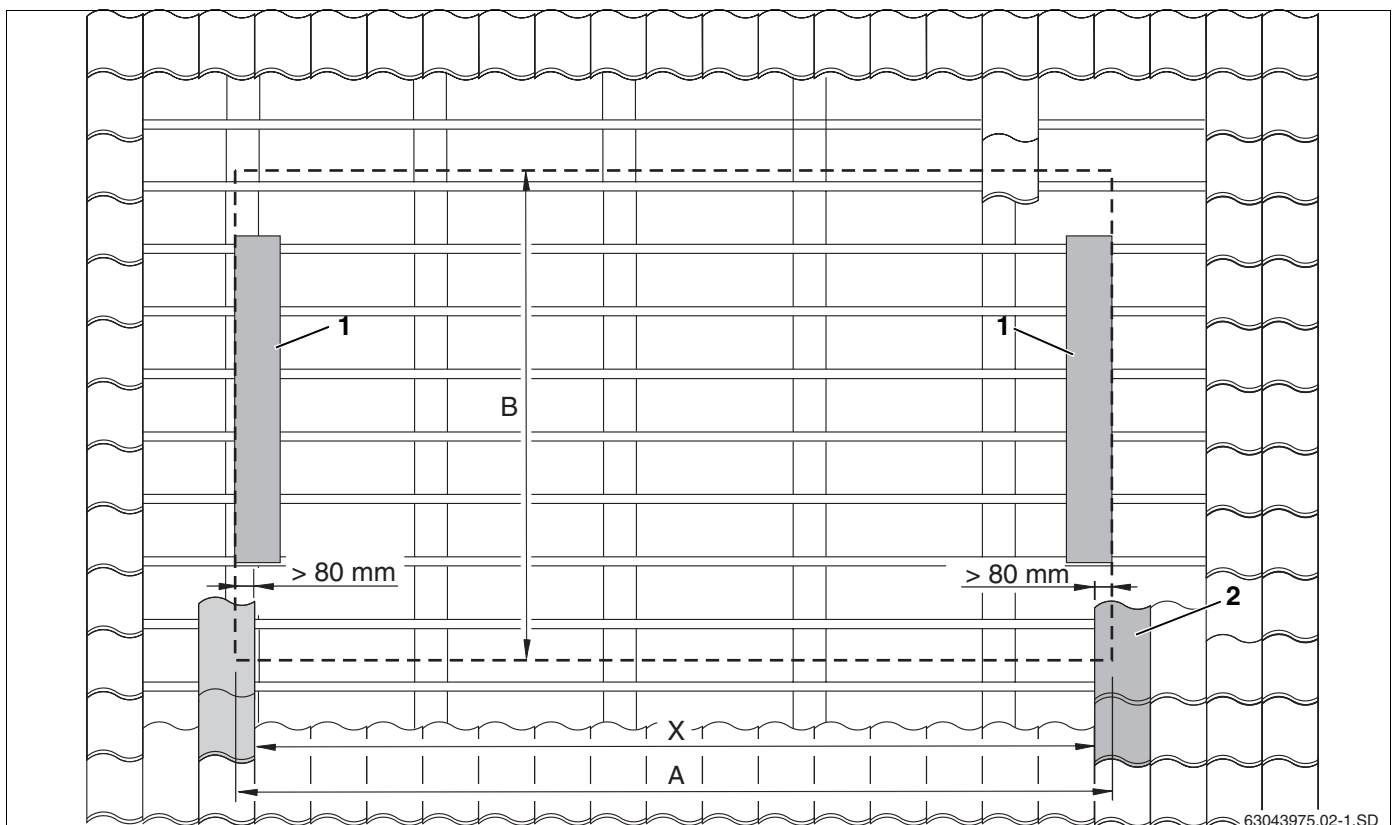

Fig. 8 Determining the exact position of the collector array

5.2 Fitting additional roof battens

When laying the facing panels and collectors additional roof battens of the same length will be required.



USER NOTE

As an alternative to additional roof battens, those already present around the collector array area can be adjusted to the same dimensions as the additional roof battens.

These instructions describe installation using additional roof battens.

Length of additional roof battens

The minimum length of additional roof battens (Fig. 9, **Item 2**) is the width of the collector array (Table 5, Page 16, dim. A) plus approx. 10 cm for the side clips (Fig. 9, **Item 1**).



BUILDING DAMAGE

from leaks in the roof.

CAUTION!

- ▶ Fasten batten butt joints to the joist or ensure that they are adequately secure, e.g. by fastening them to the already existing roof battens (Fig. 9, **Item 3** and Fig. 13, **Item 2**).

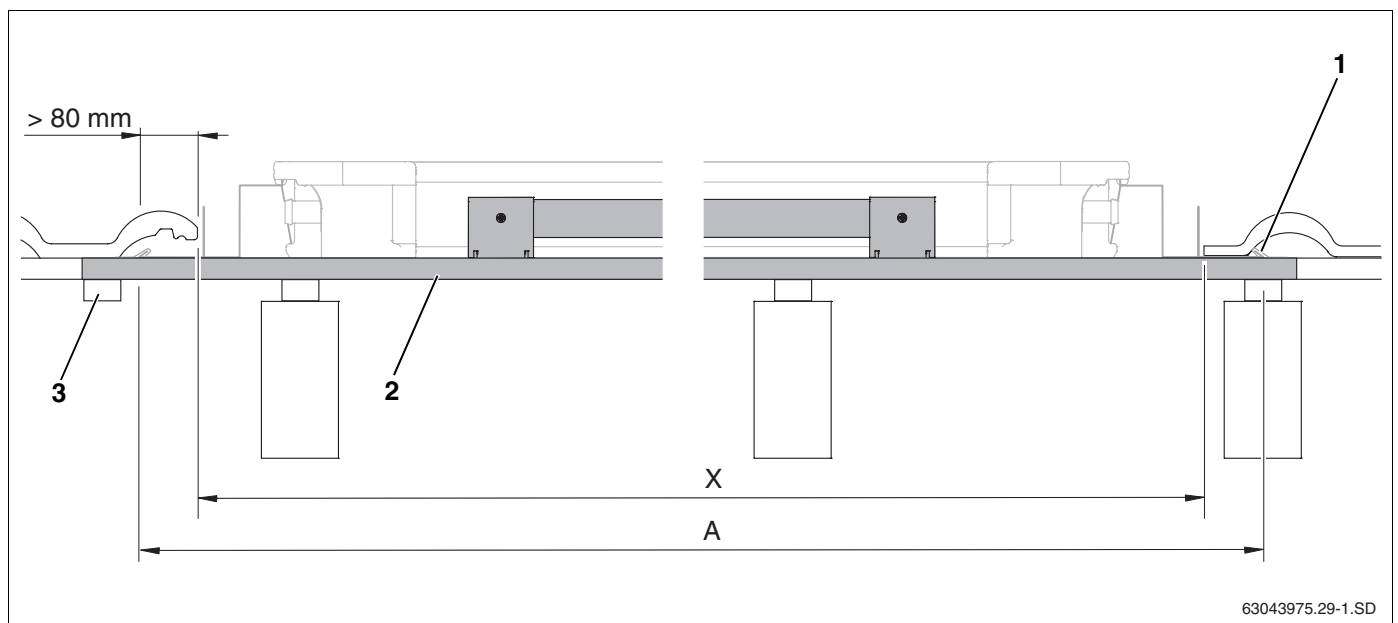

Fig. 9 Length of additional roof battens (here: first lower roof batten with anti-slip protection)

Item 1: Clip

Item 2: Additional roof battens

Item 3: Joining the additional roof battens

5.2.1 Fitting anti-slip protection devices to first additional roof batten

Due to limited space, it may not be possible for the anti-slip protection devices to be fitted directly on the roof. It so they should be pre-assembled on the ground and fitted to the first additional roof batten.



USER NOTE

For landscape installation, 3 anti-slip protection devices (Fig. 10, **Item 1**) must be fastened to one strip of wood (2 on the outside, 1 in the middle).

- ▶ Fasten two anti-slip protection devices (Fig. 10, **Item 1**) to the end of the strip of wood provided, using screws 4×10 (Fig. 10, **Item 2**).
- ▶ Place pre-assembled anti-slip protection device to the first additional roof batten (Fig. 11, **Item 2**), and fasten using two screws 4×40 (Fig. 11, **Item 1**) (observe measurements).

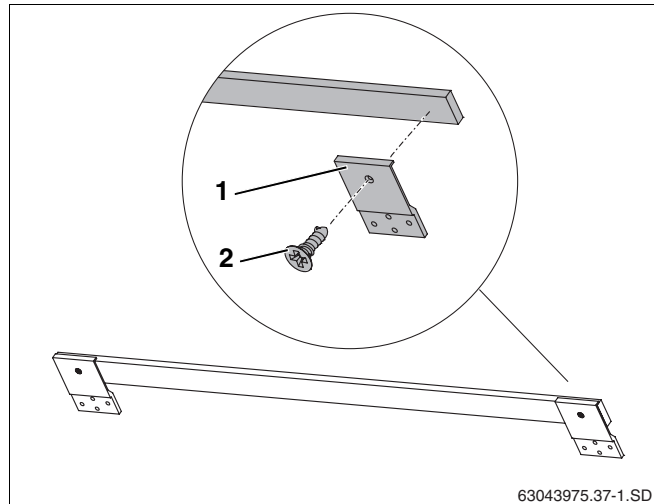

Fig. 10 Pre-assembling anti-slip protection devices with strip of wood

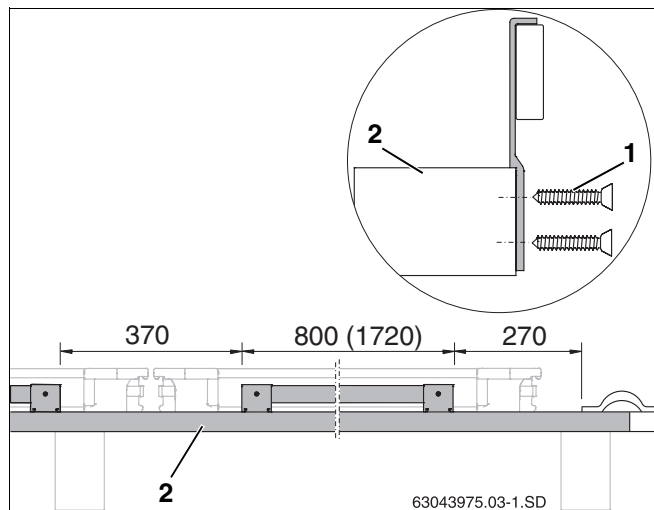

Fig. 11 Fasten anti-slip protection devices to roof batten (measurements in mm, value in brackets = landscape version)

5.2.2 Fitting additional roof battens



BUILDING DAMAGE

from leaks in the roof.

CAUTION!

- ▶ If the joists are at different levels, they must all be levelled (Fig. 12).



USER NOTE

When fitting the roof battens, make sure they are level (use spirit level).

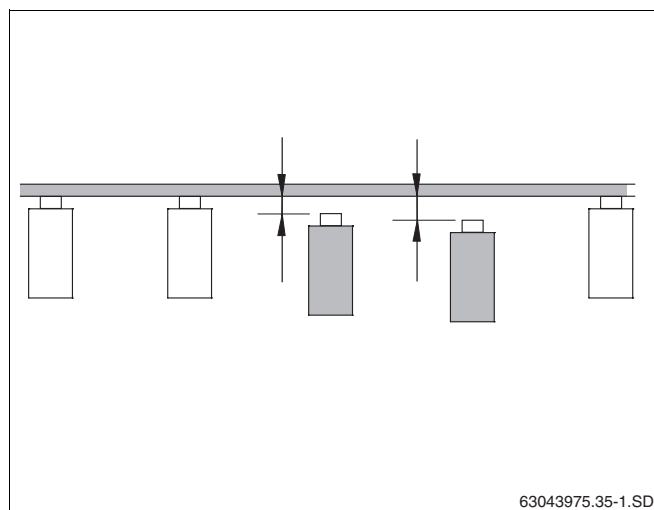

Fig. 12 Levelling the joists



USER NOTE

If an additional roof batten (Fig. 13, **Item 1**) has to be fitted near a pre-existing one, the pre-existing one must be moved near to the collector array (Fig. 13, **Item 3**) and adequately fastened (Fig. 13, **Item 2**).

The pan tiles on the side facing panels **MUST** be covered.

Installing one row

- ▶ Attach first roof batten with the anti-slip protection devices (Fig. 14, **Item 1**).
- ▶ Attach second roof batten for the lower side clamp (Fig. 14, **Item 2**).
- ▶ Attach third roof batten for the upper side clamp (Fig. 14, **Item 3**).
- ▶ Attach fourth roof batten for supporting the polystyrene wedge of the upper facing panels (Fig. 14, **Item 4**).
- ▶ Attach fifth roof batten for supporting the upper facing panels (Fig. 14, **Item 5**).
- ▶ Attach sixth roof batten for supporting and fastening the upper facing panels (Fig. 14, **Item 6**).

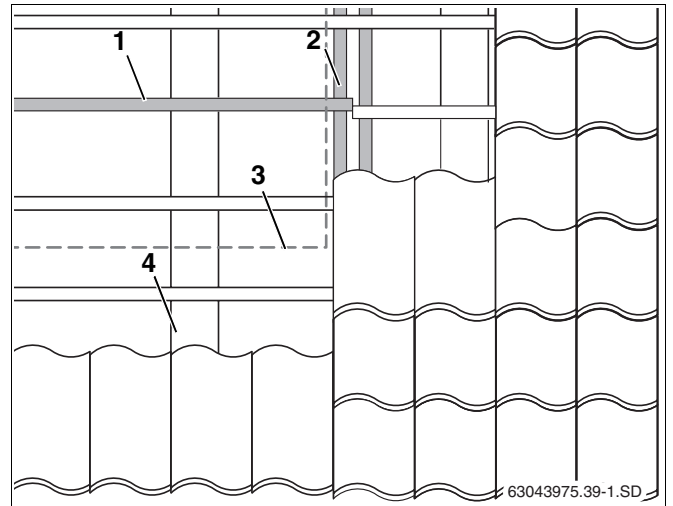

Fig. 13 Moving roof battens around the collector array area

Item 1: Moved roof batten

Item 2: Fastening for roof batten ends (counter batten)

Item 3: Collector array (outside)

Item 4: Joist

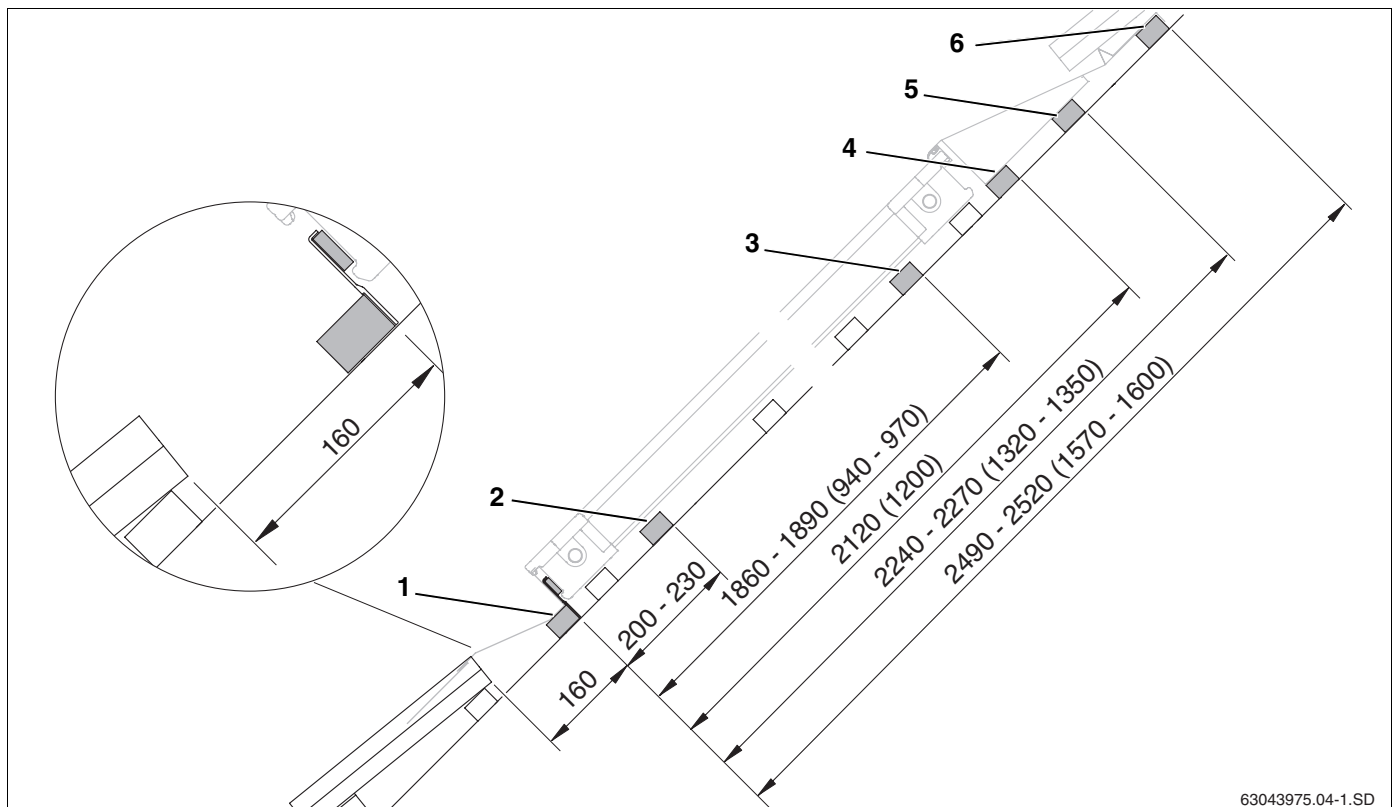

Fig. 14 Distances between additional roof battens when installing one row (measurements in mm, values in brackets = landscape version)

Installing more than one row

When installing more than one row, the roof battens in the first row must be laid as if installing one row (Fig. 14). The 5th and 6th batten for the lower row are not needed.



USER NOTE

The fourth additional roof batten (one-row installation) is also the first roof batten of the row above (Fig. 15, **Item 1**) and is required for anti-slip protection on the upper collector array.

- ▶ Attach second roof batten for the side clamp (Fig. 15, **Item 2**).
- ▶ Attach third roof batten for the upper side clamp (Fig. 15, **Item 3**).
- ▶ Attach fourth roof batten for supporting the polystyrene wedge of the upper facing panels (Fig. 15, **Item 4**).
- ▶ Attach fifth roof batten for supporting the upper facing panels (Fig. 15, **Item 5**).
- ▶ Attach sixth roof batten for supporting and fastening the upper facing panels (Fig. 15, **Item 6**).

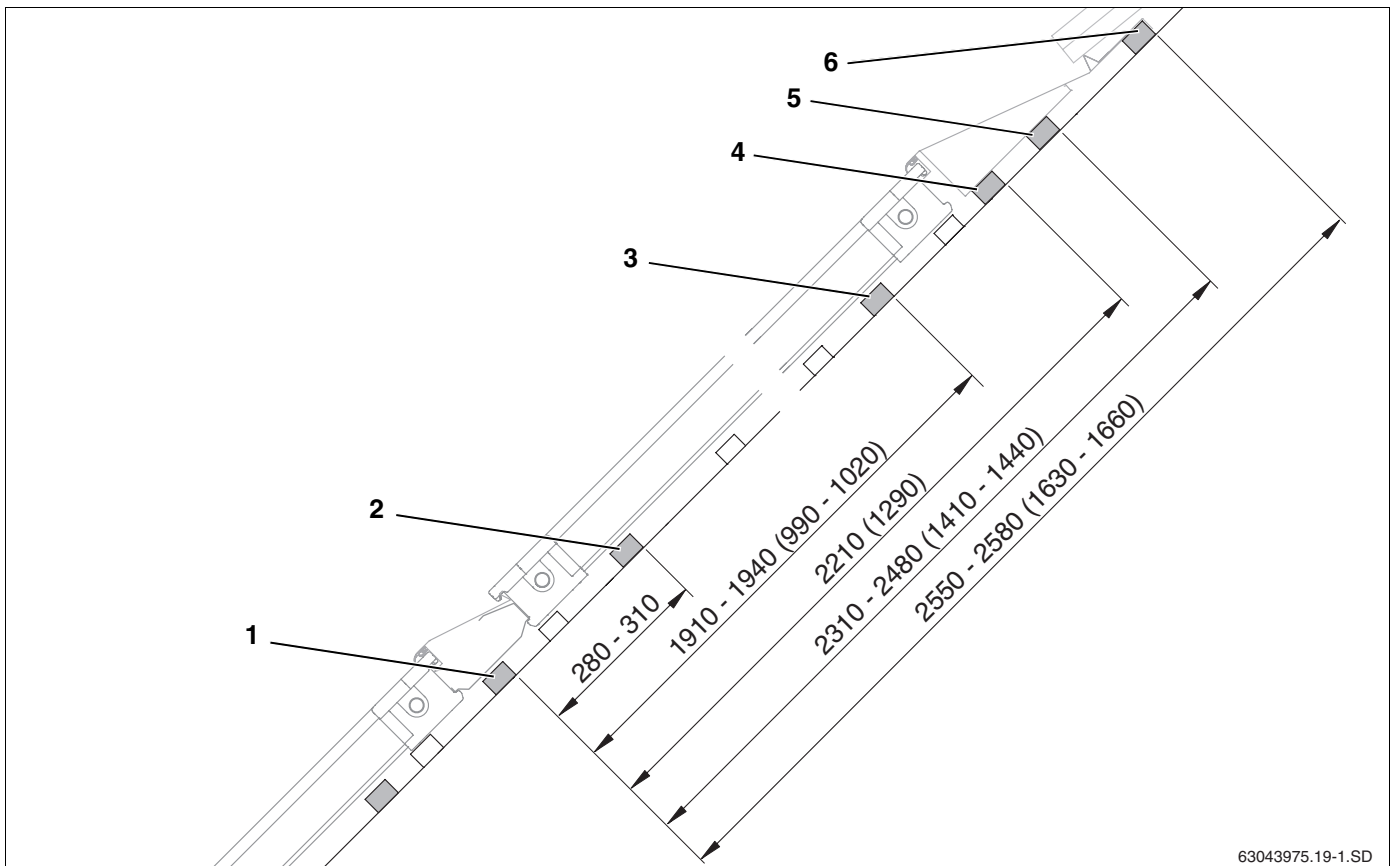

63043975.19-1.SD

Fig. 15 Distances between additional roof battens when installing more than one row (measurements in mm, values in brackets = landscape version)

6 Collector installation

Observe the following safety and user instructions when commencing the collector installation.



RISK TO LIFE

through a fall or falling parts.

WARNING!

- ▶ Take appropriate action to prevent accidents when working on roofs.
- ▶ Whilst working on the roof, take all necessary precautions against a possible fall.
- ▶ Always wear your personal protective clothing and safety equipment.
- ▶ After completing the installation, always check the secure positioning of the installed set and that of the collectors.
- ▶ Ensure that the correct equipment is used for working on roofs.



RISK OF INJURY

through interruption of work.

CAUTION!

- ▶ Secure the collectors against falling.
- ▶ Stabilise the collector array.



USER NOTE

Use lifting equipment as used by roofing contractors or sufficient suction handles for the installation.



USER NOTE

Unsecured collectors may fall during handling and installation.

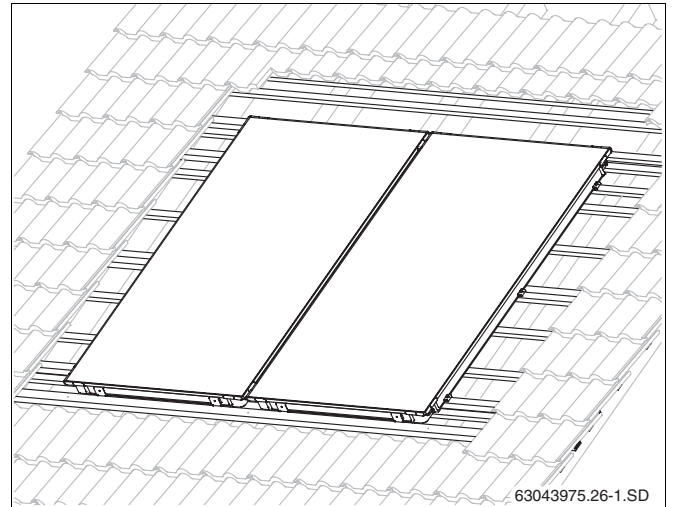

Fig. 16 Two fitted collectors

6.1 Preparing to install the collectors

Before beginning actual installation on the roof, preassemble the short solar hoses and dummy plugs on the ground to make work on the roof easier.

To secure the solar hoses, the hose clips must be fitted with the release ring.



SYSTEM DAMAGE

through leaks in the solar hoses.

CAUTION!

- ▶ The hose clip **MUST** be positioned correctly **BEFORE** the release ring (Fig. 17, **Item 1**) is removed (Fig. 17, **Item 2**). Subsequent loosening using pliers can impair resilience.



RISK OF INJURY

The release ring must only be pulled away when the hose clip is positioned over the solar hose.

CAUTION!

6.1.1 Water connection acc. to the Tichelmann principle

The collector array must be connected according to the Tichelmann principle. This ensures that each collector receives the same flow rate (Fig. 18).



USER NOTE

The flow line can be fitted to the top right (Fig. 18) or left (Fig. 19). In this manual, the flow line is shown on the right.

The collectors must be installed in such a way that the sensor pockets that receive the collector sensor (Fig. 19, **Item 1**) are at the top.



USER NOTE

If you intend to vent the solar heating system with an automatic air vent valve (accessory) at the highest point of the system, run the flow line rising to the air vent valve and the return line rising to the collector array.

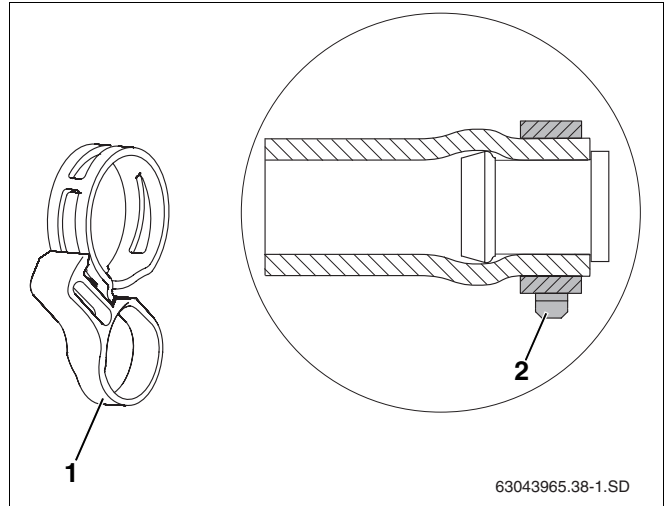

Fig. 17 Hose clip with locking ring, also shown fitted to the pre-assembled dummy plug

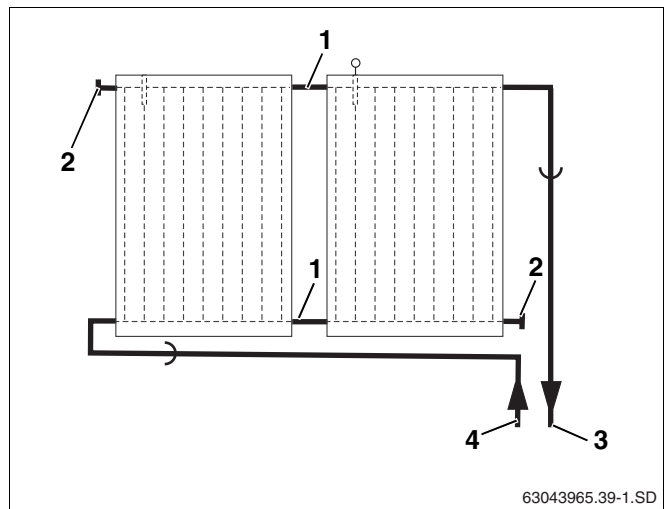

Fig. 18 Water connection – right-hand flow line

Item 1: Solar hose 95 mm

Item 2: 55 mm solar hose and dummy plug

Item 3: Flow line

Item 4: Return line

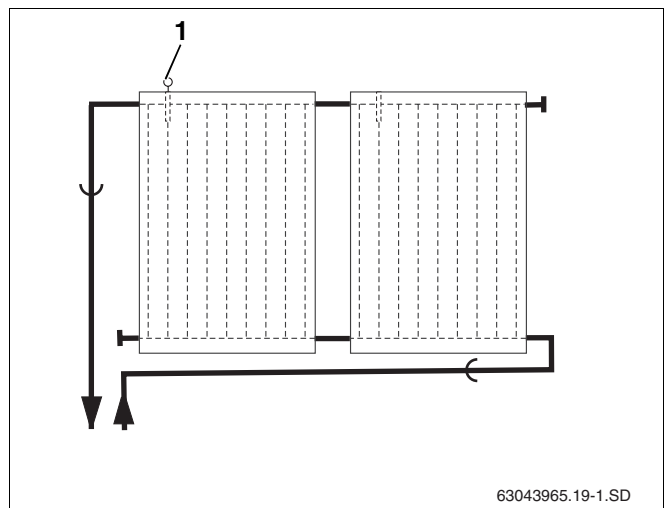

Fig. 19 Water connection – left-hand flow line

6.1.2 Preassembling connection set

The pipework connection between two collectors is made using the 95 mm solar hoses and hose clips from the connection set in the panel corner protectors.



USER NOTE

To make installation easier, we recommend that you place the solar hoses in hot water, especially when the ambient temperature is low.



USER NOTE

The illustrations show the connection set when the first collector to be installed is on the right.

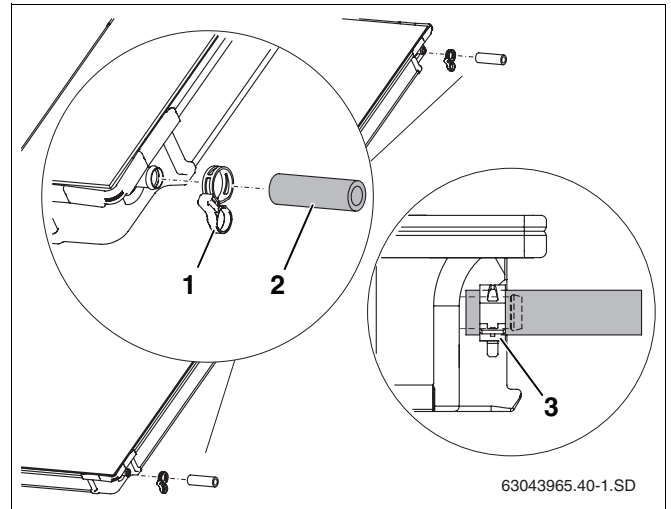

Fig. 20 Pre-assembling connection set on the second collector

- ▶ Remove plastic caps (transport protection) from the relevant collector connections.
- ▶ Push 95 mm solar hoses (Fig. 20, **Item 2**) onto the right-hand connections on the second and any subsequent collector.
- ▶ Push hose clips (Fig. 20, **Item 1**) over the solar hose (the second clip will enable the other collector to be connected later).
- ▶ Once the hose clip is sitting correctly, pull the quick release ring to secure the connection (Fig. 20, **Item 3**).

6.1.3 Dummy plug installation

Not all the connections are needed when connecting a collector array, so those that are not used must be closed.

- ▶ Remove plastic caps (transport protection) from the relevant collector connections.
- ▶ Put 55 mm solar hoses (Fig. 22, **Item 2**) together with the pre-assembled dummy plug onto the two free connections on the collector array.
- ▶ Once the hose clips are sitting correctly, pull the quick release rings to secure the connection.

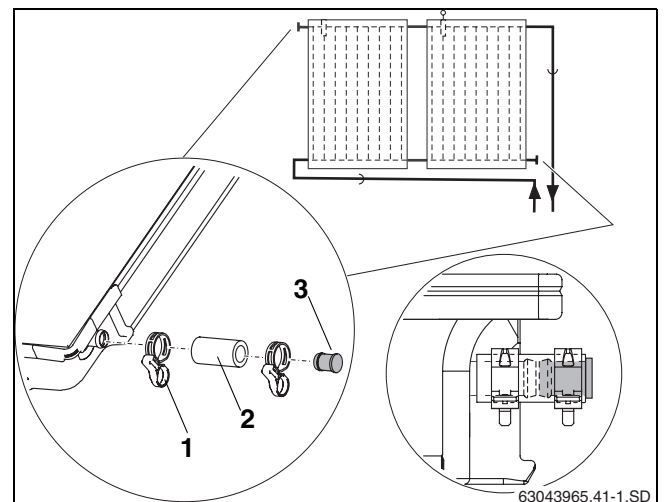

Fig. 21 Fitting the dummy plug and hose clip

Item 1: Hose clip

Item 2: Solar hose 55 mm

Item 3: Dummy plug

6.1.4 Fitting angled nozzles for header pipes

To prepare the connection on the header pipes, pre-assemble the angled nozzles.

- ▶ Remove plastic caps (transport protection) from the relevant collector connections.
- ▶ Push nut (Fig. 22, **Item 1**) over the collector connections.
- ▶ Place the clamping disc (Fig. 22, **Item 2**) behind the head on the collector connection and press together.
- ▶ Align angled nozzle (Fig. 22, **Item 3**) and bolt together with nut.

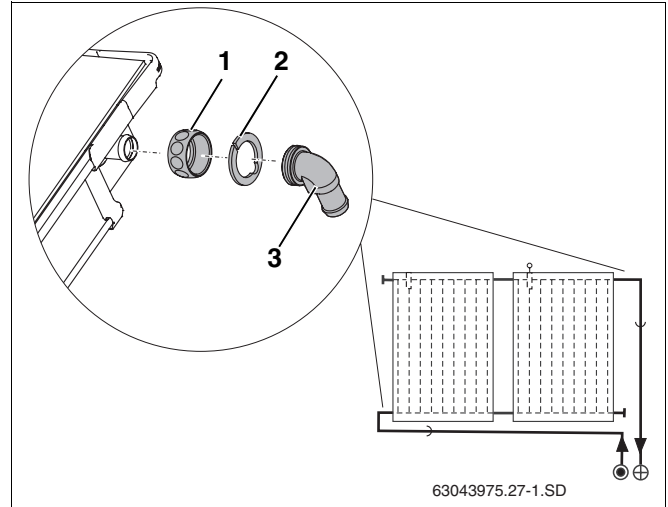

Fig. 22 Fitting angled nozzles

6.1.5 Inserting sealing tape in collector frame

The connections between the side and lower facing panels and the collectors (Fig. 23, **Item 1**) must be sealed with the sealing tape.

- ▶ Clean the recessed channel on the collector.
- ▶ Remove protective film from the sealing tape
- ▶ Insert sealing tape (Fig. 23, **Item 2**) adhesive side first into the recessed channel on the outer edges of the outer collectors and at the bottom of every collector (Fig. 23, **Item 1**) incl. the corner connector (Fig. 23, **Item 3**).

The sealing tape slowly swells after installation.

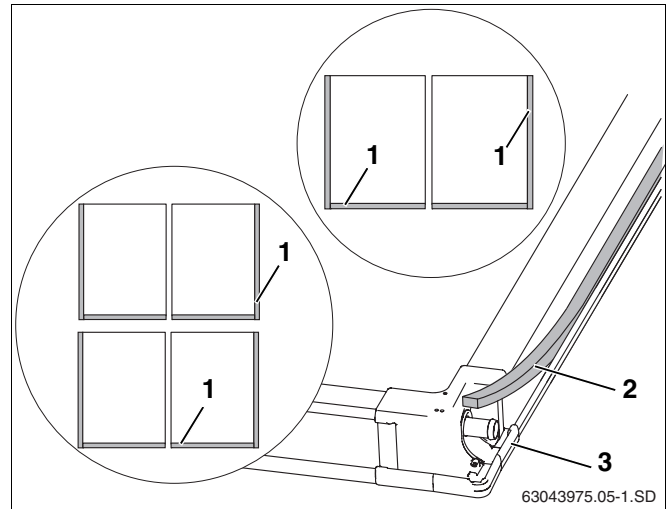

Fig. 23 Back of the collector

6.2 Fastening the collectors

Begin laying the collectors on the right-hand side.

6.2.1 Laying first collector

- ▶ Allow first collector (Fig. 24, **Item 1**) to slide into place in the anti-slip protection device and position 100 mm from the outer (cut if necessary) pan tile (Fig. 24, **Item 2**).

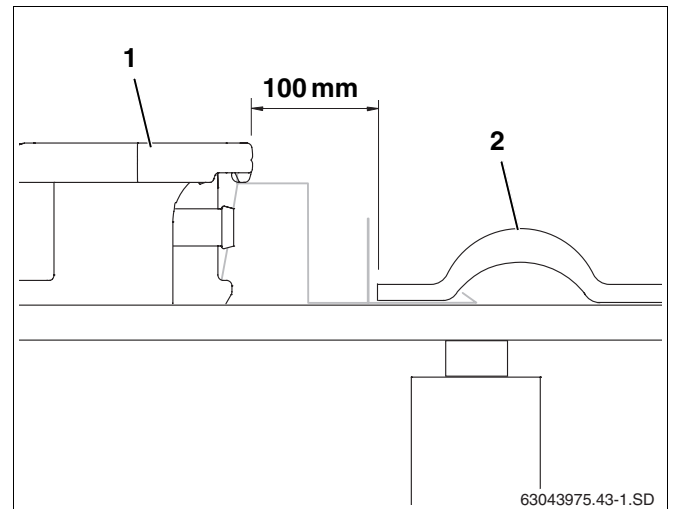

Fig. 24 Laying first collector and screwing in place

- ▶ Lift collector slightly and, on the 2nd and 3rd additional battens, as well as halfway along the collector on a free batten, push the right-hand pack plates (Fig. 25, **Item 3**) under the collector until the roof pushes against the lower edge of the collector.
- ▶ For the screw (Fig. 25, **Item 1**) drill a pilot hole with a 4 mm drill.
- ▶ Fasten the single-sided clamps (Fig. 25, **Item 2**) with a 6x40 screw (Fig. 25, **Item 1**) and washer (use size 10 spanner).

The clamp now grips into the lower edge of the collector.

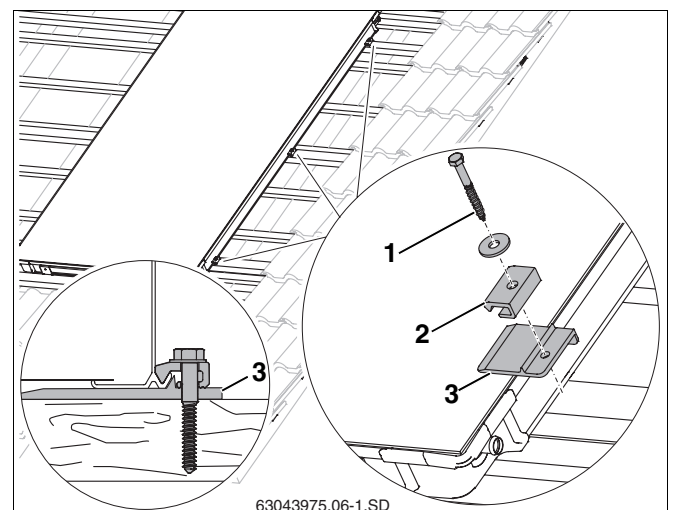

Fig. 25 Laying first collector and screwing in place

- ▶ Lift collector slightly and, on the 2nd and 3rd additional battens, as well as halfway along the collector on a free batten, push the pack plate (Fig. 26, **Item 2**) with the double-sided clamp under the collector until the roof pushes against the lower edge of the collector.
- ▶ For the screw (Fig. 26, **Item 1**) drill a pilot hole with a 4 mm drill. To mark position, use notch in the pack plate.



USER NOTE

Do not tighten the screw until the second collector has been pushed up against the double-sided clamp.

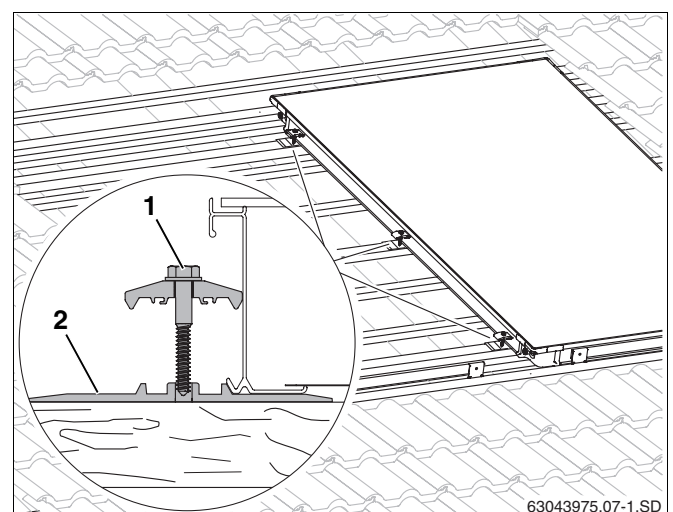

Fig. 26 Double-sided clamp on the first collector

6.2.2 Putting the second collector in place

- ▶ Allow the second collector and the pre-assembled solar hoses (Fig. 27, **Item 1**) to slide into the anti-slip protection device.
- ▶ Push the second hose clip (Fig. 27, **Item 2**) onto the solar hose.
- ▶ Push the second collector towards the first collector in such a way that the preassembled solar hoses are pushed onto the left-hand connections on the first collector (Fig. 27, **Item 3**).

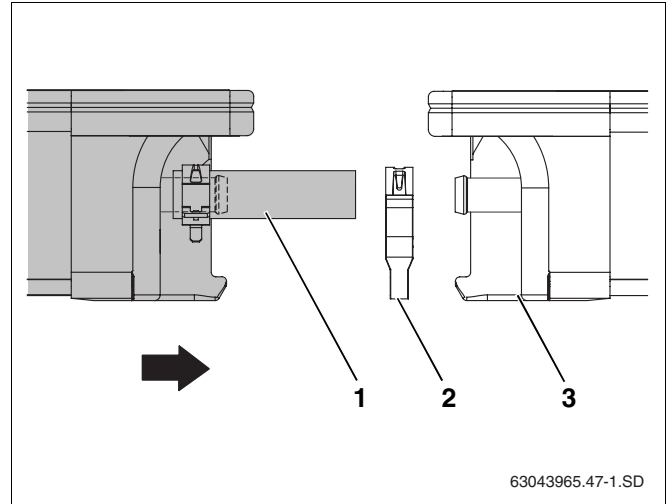

Fig. 27 Joining second collector with the first

- ▶ Push the hose clip over the bead on the collector connection and pull the locking ring.



SYSTEM DAMAGE

from unsecured solar hoses.

CAUTION!

- ▶ Secure every solar hose to the collector connection using a hose clip (Fig. 28).

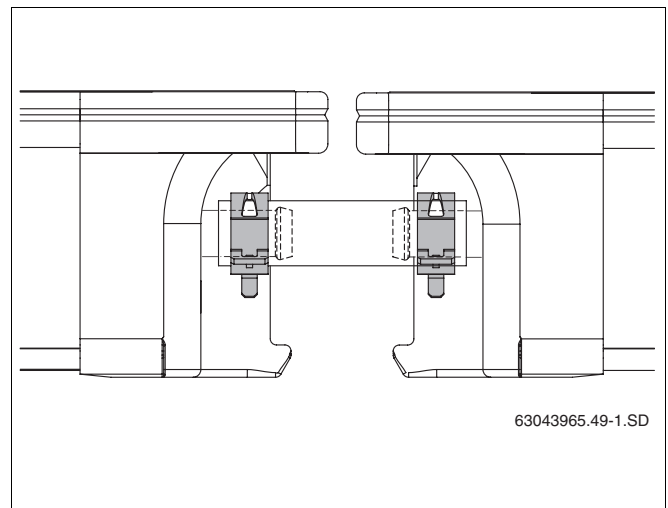

Fig. 28 Solar hose with secured hose clips

- ▶ Tighten the screw on the double-sided clamp (Fig. 29, **Item 1**). You will need an extension at least 80 mm in length.

The clamp now grips into the lower edges of the collector.

Repeat the procedure for all other collectors.

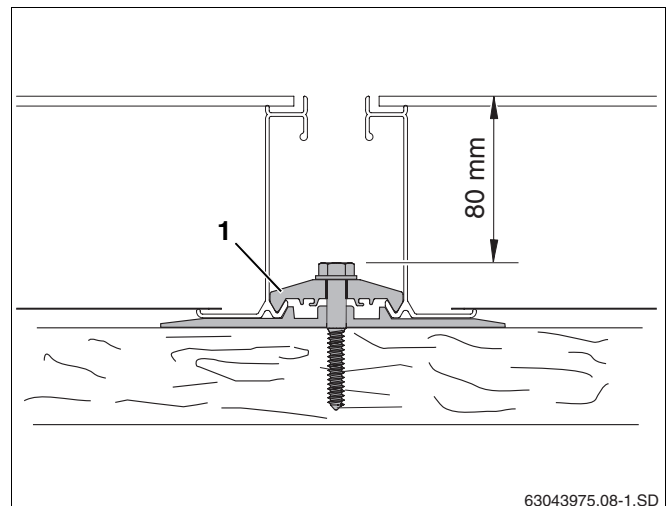

Fig. 29 Screwing in double-sided clamp

6.2.3 Securing the last collector

- ▶ Lift left-hand collector slightly and, on the 2nd and 3rd additional battens, as well as halfway along the collector on a free batten, push the left-hand pack plates (Fig. 30, **Item 3**) under the collector until the roof pushes against the lower edge of the collector.
- ▶ For the screw (Fig. 30, **Item 1**) drill a pilot hole with a 4 mm drill.
- ▶ Fasten the single-sided clamps (Fig. 30, **Item 2**) with a 6x40 screw (Fig. 30, **Item 1**) and washer (use size 10 spanner).

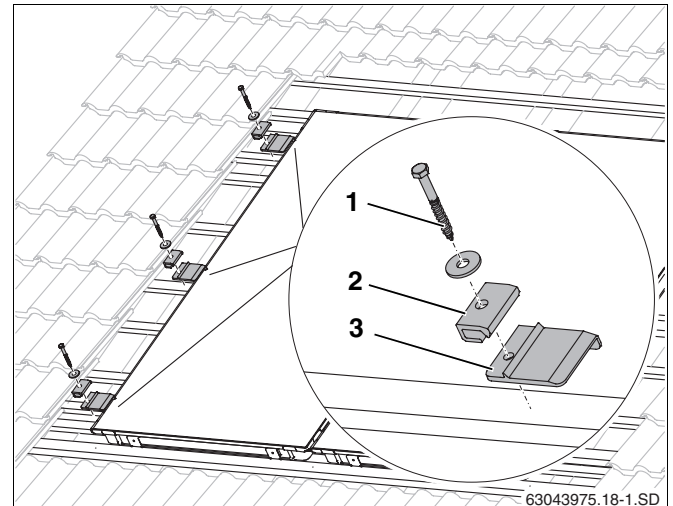

Fig. 30 Fitting the left-hand clamps

6.2.4 Installing more than one row

If you intend to install more than one collector array, one above the other, anti-slip protection devices must be fitted for the upper collectors.



USER NOTE

For the landscape version, 3 anti-slip protection devices must also be fitted 700 mm apart, halfway along the collector.

- ▶ Put two anti-slip protection devices (Fig. 31, **Item 1**) per collector, halfway along (700 mm apart) over the lower collector onto the fourth additional batten on the lower row, and fasten with two 4x40 screws.
- ▶ Allow the collectors in the upper row (Fig. 31, **Item 2**) to slide against the anti-slip protection devices and align with the lower row.
- ▶ Fasten collectors as with the lower row.

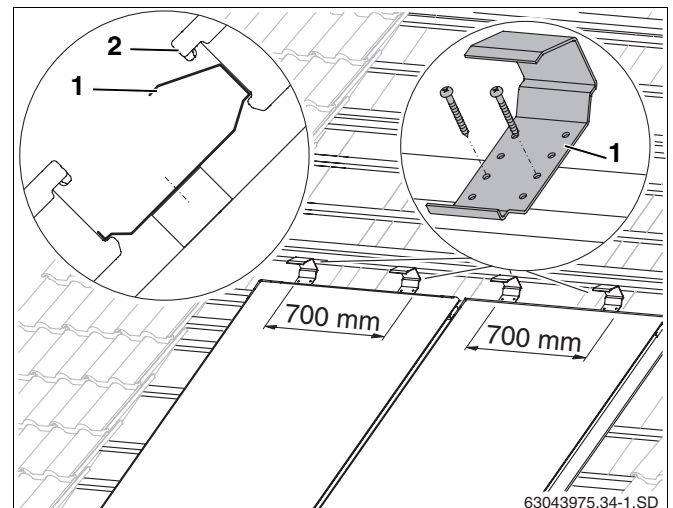

Fig. 31 Anti-slip protection devices for the second collector array

7 Collector sensor connection



USER NOTE

The collector sensor is supplied with the solar controller.

Observe the installation location for single or dual row collector systems (Fig. 32).

Insertion point

The collector sensor must be fitted in the collector nearest to the flow connection (Fig. 32, **Item 2**).

- Insertion point (Fig. 32, **Item A**) for single row collector systems with right-hand flow line.
- Insertion point (Fig. 32, **Item B**) for double row collector systems with left-hand flow line.

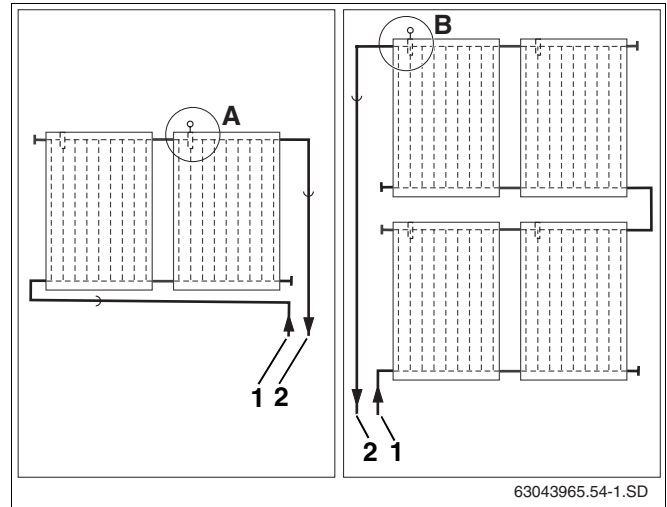

Fig. 32 Collector sensor installation location (schematic)

Item 1: Return line

Item 2: Flow line

Installing the collector sensor

For perfect functioning of the solar heating system, the collector sensor (Fig. 33, **Item 1**) needs to be inserted into the sensor guide tube as far as it will go (approx. 250 mm).

- ▶ Using the collector sensor or screwdriver, push through the sealing membrane on the sensor bush (Fig. 33, **Item 3**).
- ▶ Screw clamped joint (Fig. 33, **Item 2**) into sensor bush.
- ▶ Insert collector sensor approx. 250 mm into the sensor guide tube (as far as it will go).
- ▶ Tighten clamped joint (Fig. 33, **Item 2**), counterhold if necessary.



USER NOTE

If you accidentally push through the sensor bush (Fig. 33, **Item 3**) on the wrong collector, it can be resealed using the plug from the connection kit. You must first remove the nut in the sensor bush using the cable gland (Fig. 33, **Item 2**).

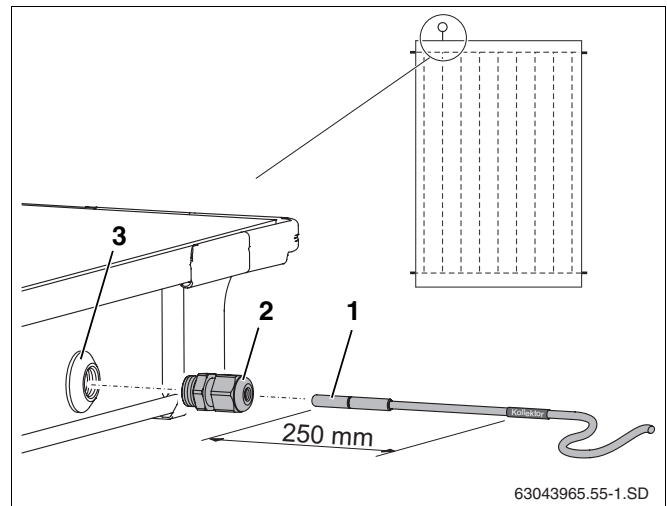

Fig. 33 Pushing the collector sensor into the collector

Item 1: Collector sensor

Item 2: Clamped joint

Item 3: Sensor bush

8 Header connection

Information on laying the header pipes can be found in the complete station installation instructions.

The water connection to the header pipes is made using the long flexible solar hoses. It is not permitted to connect a fixed header pipe directly to the collector.

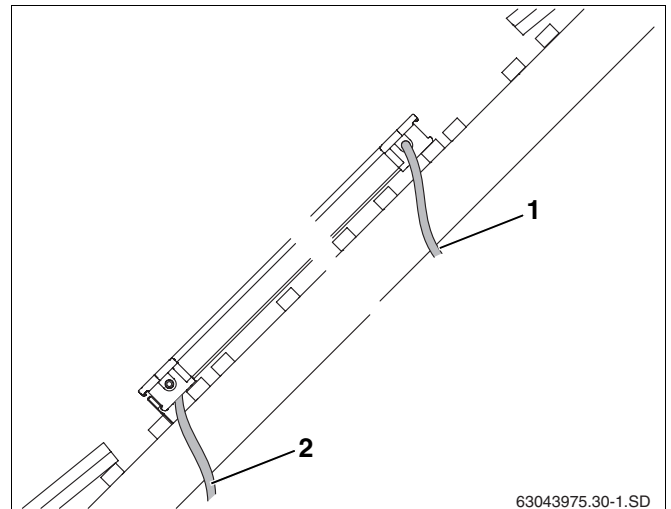

Fig. 34 Routing connection pipes under the roof

Item 1: Flow line

Item 2: Return line

8.1 Venting through pressure filling

If venting of the solar heating system is carried out using a pressure filling pump, no vent is required on the roof.

- ▶ Remove plastic caps (transport protection) from the relevant collector connections.
- ▶ Push nut (Fig. 35, **Item 1**) over the collector connections.
- ▶ Place the clamping disc (Fig. 35, **Item 2**) behind the head on the collector connection and press together.
- ▶ Press angled nozzle with O-ring (Fig. 35, **Item 3**) onto connection, align and bolt together with nut.
- ▶ Push long solar hose (1000 mm, Fig. 35, **Pos. 5**) onto the angled nozzle and fix in place using hose clip (Fig. 35, **Item 4**).
- ▶ Insert hose nozzle with compression fitting (Fig. 35, **Item 6**) into the solar hose as far as it will go, and fix in place with hose clip.
- ▶ Feed solar hose together with the sensor cable through the roof.
- ▶ Connect header pipe to the R $\frac{3}{4}$ hose nozzle with compression fitting (22 mm) (Fig. 35, **Item 6**).

Perform the same procedure with the return connection.

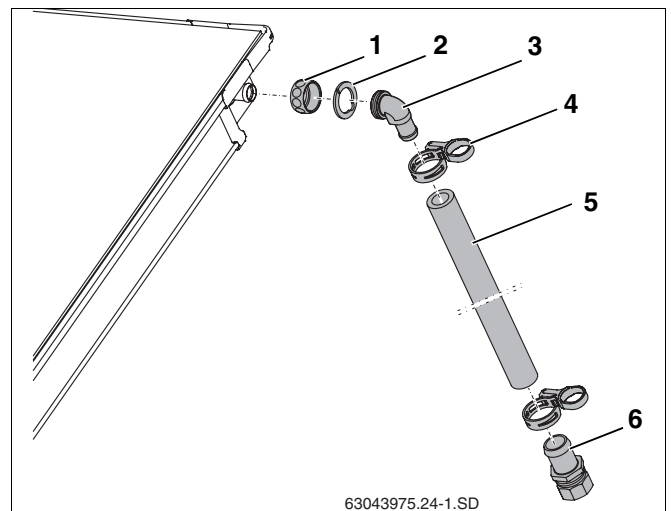

Fig. 35 Fitting flow line

Item 1: Nut

Item 2: Clamping disc

Item 3: Angled nozzle with O-ring

Item 4: Hose clip

Item 5: Solar hose 1000 mm

Item 6: R $\frac{3}{4}$ hose nozzle with 22 mm compression fitting

8.2 De-airing through air vent (accessory) at highest point in the system

If you intend to vent the solar heating system with an automatic air vent valve (accessory) at the highest point of the system, run the flow line rising to the air vent valve (Fig. 36, **Item 2**) and the return line rising to the collector array (Fig. 36).

Avoid frequent changes in direction.



User note:

For each change of direction downwards and each new rise, install an additional air pot with air vent.

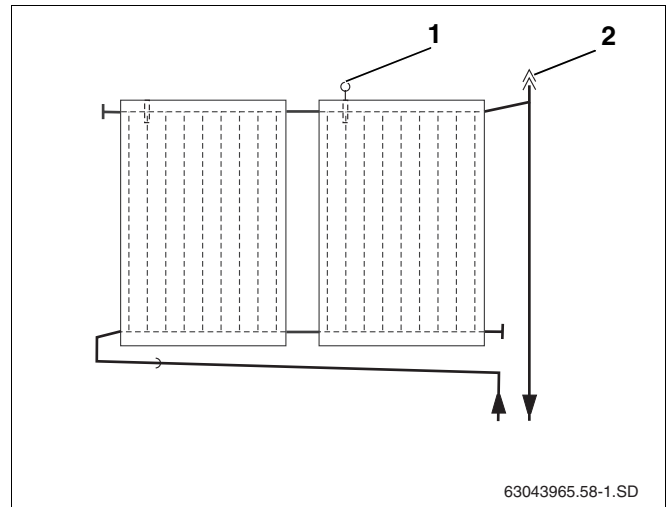

Fig. 36 Air vent for flow connection

Item 1: Collector sensor

Item 2: Automatic air vent valve at highest point in the system

Function of the weather protection cap and weather protection cap on the automatic air vent valve

The solar heating system is vented through the opened weather protection cap (Fig. 37, **Item 1**). When in operation, the weather protection cap (Fig. 37, **Item 1**) must always be positioned over the weather protection cap to prevent moisture entering through the opened weather protection cap into the solar heating system.

Open the air vent valve by unscrewing the weather Protection cap one full revolution.



User note:

The air vent set is designed for fitting the vent directly to the collector or under the roof, however with in roof panels the airvent must be fitted under the roof.

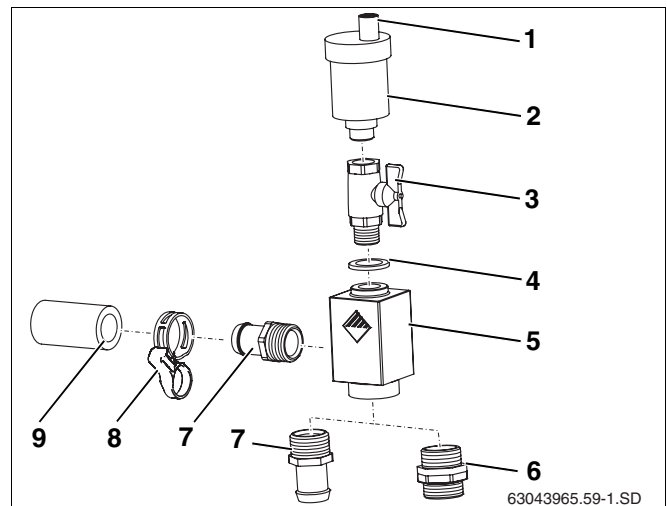

Fig. 37 Universal air vent set

Item 1: Weather protection cap

Item 2: Automatic air vent

Item 3: Ball valve

Item 4: Gasket

Item 5: Vent pot

Item 6: Double threaded fitting threaded fitting with nut and clamping ring

Item 7: Hose nozzle with O-ring (not required here)

Item 8: Hose clip

Item 9: Solar hose 55 mm (not required here)

Connecting the air vent valve under the roof

- ▶ Remove plastic caps (transport protection) from the relevant collector connections.
- ▶ Push nut (Fig. 38, **Item 1**) over the collector connections.
- ▶ Place the clamping disc (Fig. 38, **Item 2**) behind the head on the collector connection and press together.
- ▶ Align angled nozzle with O-ring (Fig. 38, **Item 3**) and join with nut.
- ▶ Push long solar hose (1000 mm, Fig. 38, **Pos. 5**) onto the angled nozzle and fix in place using hose clip (Fig. 38, **Item 4**).
- ▶ Feed solar hose together with the sensor cable through the roof.

Perform the same procedure with the return connection.

- ▶ Screw R $\frac{3}{4}$ hose nozzle with O-ring (Fig. 38, **Item 6**) and double threaded fitting with O-ring (Fig. 38, **Item 8**) into the air pot (Fig. 38, **Item 7**).
- ▶ Push hose nozzle (Fig. 38, **Item 6**) onto the solar hose as far as it will go and fix in place using hose clip.



USER NOTE

For the return connection must fit the hose nozzle and compression fitting (from the connection kit) into the long solar hose.

- ▶ Connect header pipe to the compression fitting (Fig. 38, **Item 8**).

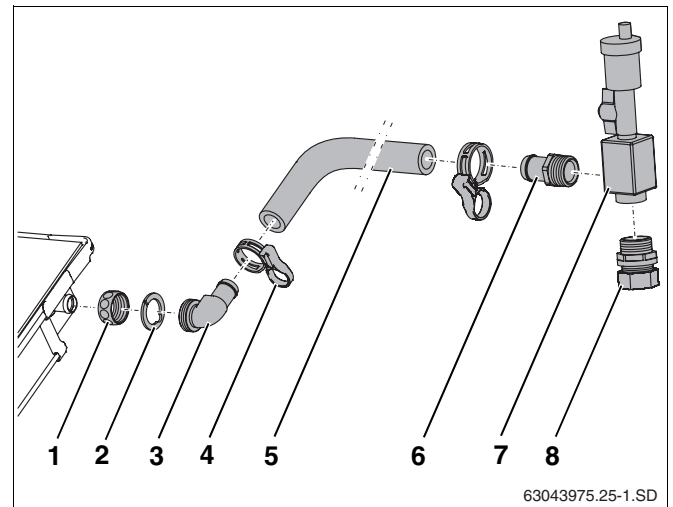

Fig. 38 Fitting the solar hose to the flow connection

Item 1: Nut

Item 2: Clamping disc

Item 3: Double threaded fitting with O-ring

Item 4: Hose clip with locking ring

Item 5: Solar hose 1000 mm

Item 6: R $\frac{3}{4}$ hose nozzle with O-ring

Item 7: Air pot

Item 8: Double threaded fitting with O-ring and compression fitting

9 Fitting the connection set for two rows (accessory)

The connection set (Fig. 39, **Item 8**) is available as an accessory, and connects two rows of collectors. Additional unused outlets are closed off with dummy plugs (Fig. 39, **Item 9**).



USER NOTE

Fit all connection parts to the collectors on the ground.

Parts included (Fig. 39)

Item 1:	Angled nozzle	2 x
Item 2:	Hose clip	4 x
Item 3:	Dummy plug	2 x
Item 4:	Solar hose 55 mm	2 x
Item 5:	Solar hose 1000 mm	1 x
Item 6:	Nut	2 x
Item 7:	Clamping disc	2 x

Fitting additional dummy plugs

Use the dummy plugs to close up any collector connections not in use (Fig. 40, **Item 1**).

- ▶ Place 55 mm solar hoses (Fig. 40, **Item 3**) together with the preassembled dummy plugs onto the two free connections.
- ▶ Once the hose clips are sitting correctly, pull the release rings to secure the connection.

Installing the connection set

- ▶ Remove plastic caps (transport protection) from the relevant collector connections.
- ▶ Push union nut (Fig. 41, **Item 1**) over the collector connections.
- ▶ Place the clamping disc (Fig. 41, **Item 2**) behind the head on the collector connection and press together.
- ▶ Press angled nozzle with O-ring (Fig. 41, **Item 3**) onto connection, align and join with nut.
- ▶ Measure distance between the angled nozzles (dim. X) once the collectors are installed, and cut the solar hose (Fig. 41, **Item 5**) to size accordingly.
- ▶ Attach solar hose to the angled nozzles and secure using hose clips (Fig. 41, **Item 4**).

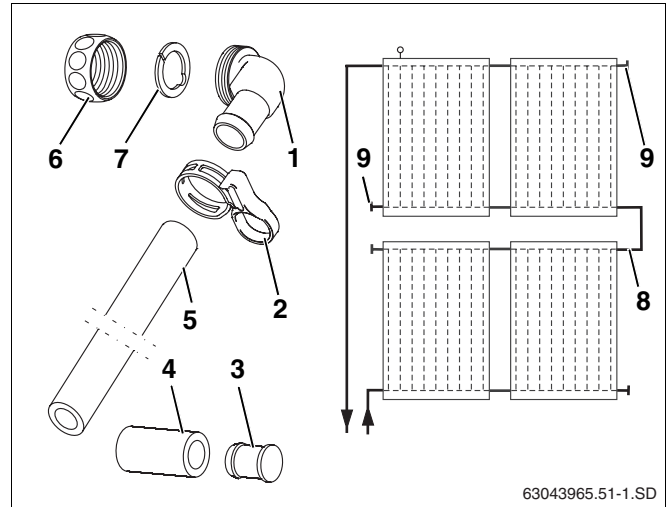

Fig. 39 Schematic diagram and parts included

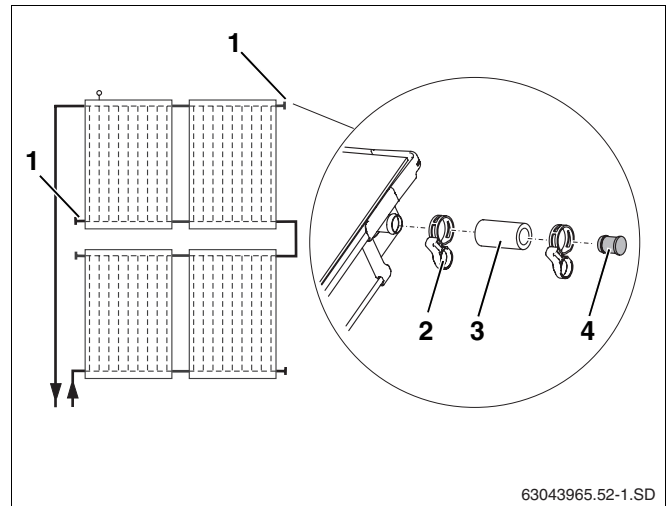

Fig. 40 Fitting the preassembled dummy plugs

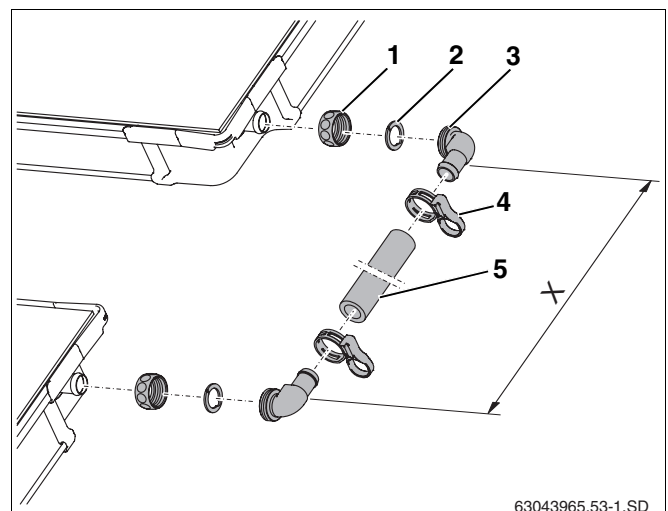

Fig. 41 Connection set between two collector rows

10 Installing the facing panels

Before you block access to the collector array with the facing panels, you must carry out the following checks:

1.	Solar hoses secured with hose clips (locking ring pulled)?	<input type="checkbox"/>
2.	Every collector secured on the left and right with clamps?	<input type="checkbox"/>
3.	Sensor inserted as far as it will go and secured with clamped joint?	<input type="checkbox"/>
4.	Pressure test carried out and all connections leak-proof (see pump station instructions)?	<input type="checkbox"/>

To seal the collector array, facing panels must be fitted around and between the collectors/collector arrays.



BUILDING DAMAGE

from leaks in the roof.

CAUTION!

- ▶ Fit the facing panels very carefully, so that no leaks can occur through the collector array.



RISK OF INJURY

Like other components incorporated into the roof, the space between the collector and the pan tiles is covered with thin panels. These can cause injuries.

CAUTION!

- ▶ Wear suitable gloves to protect your hands.



USER NOTE

For landscape installation, the lower, middle and upper facing panels do not overlap between two collectors (Fig. 42, **Item 1**), but instead in the middle of a collector.

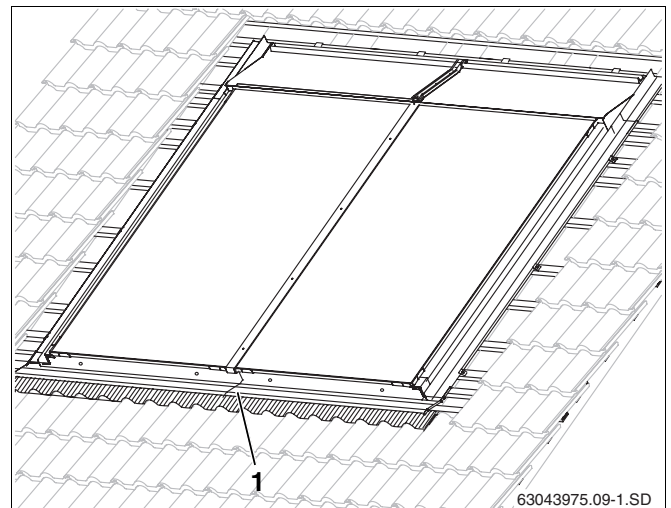

Fig. 42 Facing panels fitted all round the edges

10.1 Lower facing panels

- ▶ Bend flashing for all facing panels towards the front (Fig. 43, **Item 2**).
- ▶ Likewise, lay the ends of the upper outer facing panels (Fig. 43, **Item 1**) towards the front.

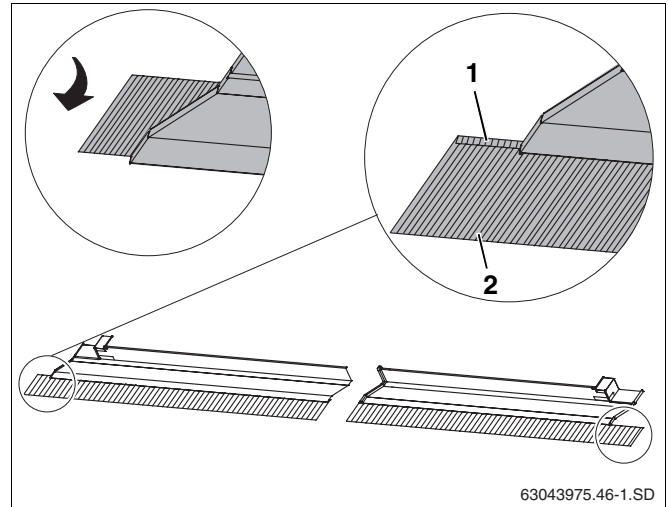

Fig. 43 Laying flashing



CAUTION!

BUILDING DAMAGE

from roof leaks, if the distance between upper edge of the collector to the upper edge of the first additional roof batten is not 90–92 mm.

- ▶ You must underlay the roof batten if required.
- ▶ Insert upper edge of the right-hand facing panel into the recessed channel on the collector (Fig. 44, **Item 3**).
- ▶ Push facing panel towards the collector so that the short edge on the right (Fig. 44, **Item 1**) grips up into the recessed channel on the collector.

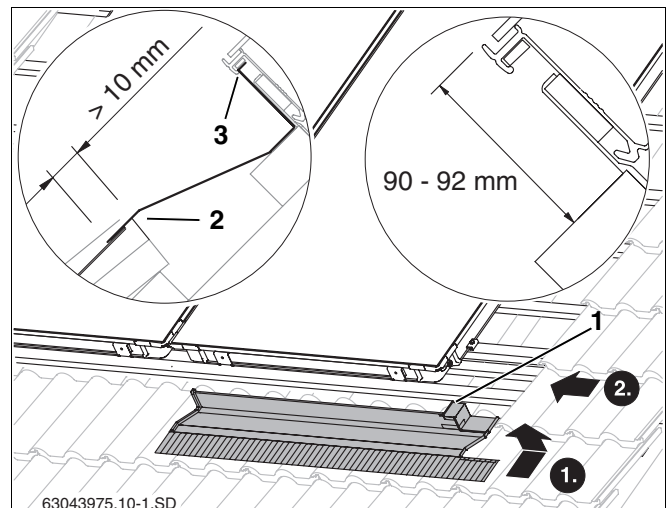

Fig. 44 Lower right facing panel



USER NOTE

The facing panel must overlap the pan tile by at least 10 mm (Fig. 44, **Item 2**).



USER NOTE

Lower middle facing panels (Fig. 45, **Item 1**) are required for more than two portrait collectors. They must be fitted flush with the collector on their left side (arrow).

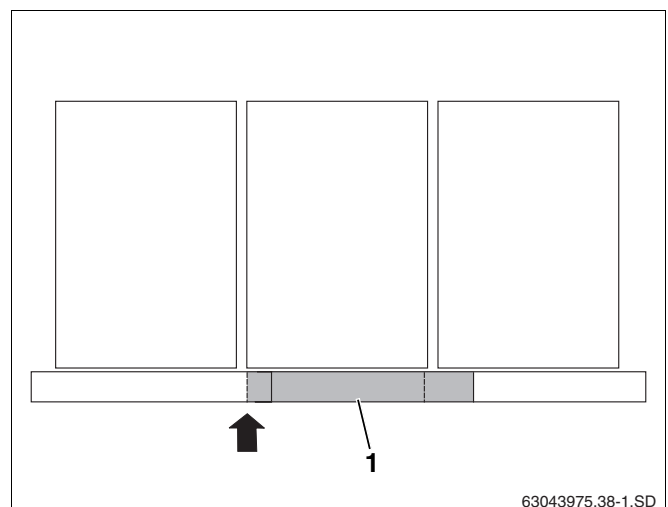

Fig. 45 Positioning the middle facing panels for portrait collectors

**USER NOTE**

For two landscape collectors, facing panels are necessary underneath in the middle (Fig. 46, **Item 1**). They must overlap by 80–100 mm.

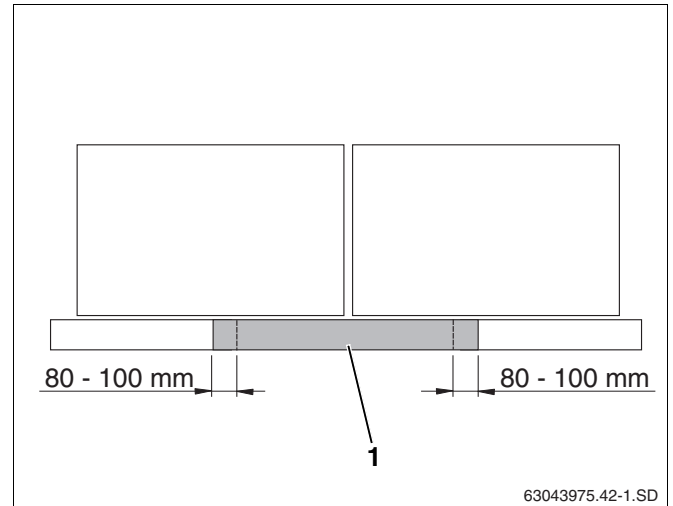

Fig. 46 Positioning the middle facing panels for landscape collectors

- Lay the left-hand facing panel (Fig. 47, **Item 2**) on the previous one, and fit in the same way as the right-hand one (Fig. 44).

**USER NOTE**

Do not remove protective film from the adhesive on the facing panels (Fig. 47, **Item 1**) until all panels are screwed on.

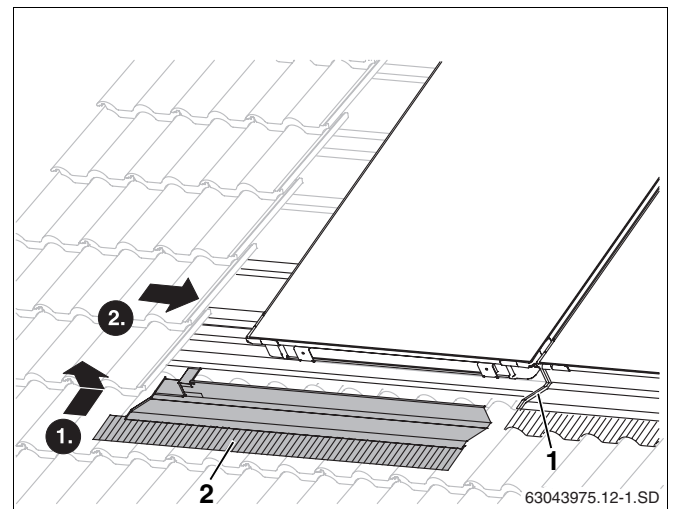

Fig. 47 Fitting the left-hand lower facing panel

- Fasten the panels with screws (12 mm long, Fig. 48, **Pos. 1**) and sealing discs in the centre punch marked on the panel.
- Remove protective film from the adhesive on the facing panels.
- Press the upper facing panel down onto the lower one (Fig. 48, **Item 3**).
- Remove protective film from the back of the flashing.
- Carefully adjust flashing in the area in front of the roof tile contour (Fig. 48, **Item 2**).

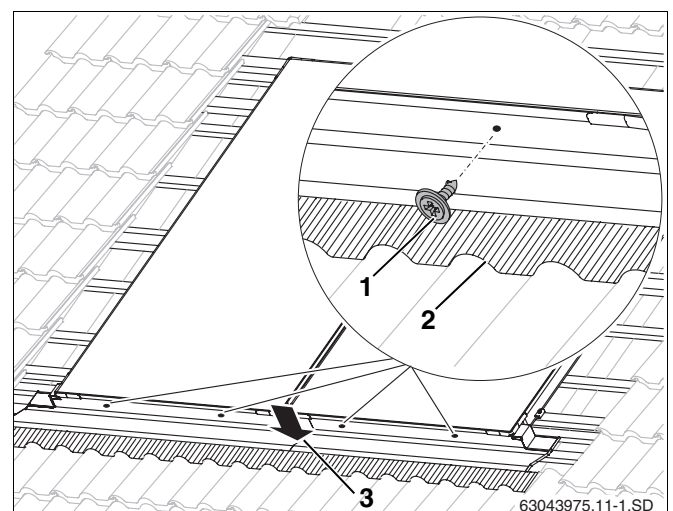

Fig. 48 Fastening the lower panels

10.2 Side facing panels



BUILDING DAMAGE

from leaks in the roof.

CAUTION!

- ▶ Place the mounting plates (Fig. 49, **Item 2**) into the lower edge of the collector.
- ▶ Place the edge of the right and left side facing panels (Fig. 49, **Item 1**) up into the recessed grip on the collector and push in over the lower facing panel.
- ▶ Press the fold overlap on both panels together to fix in place (Fig. 49, **Item 3**).

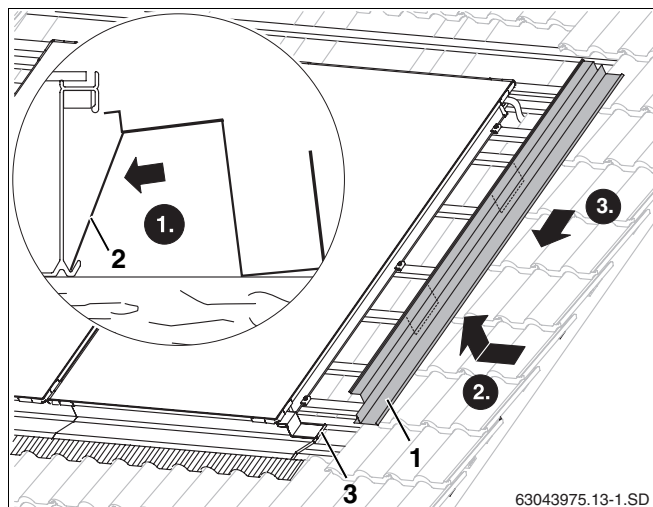

Fig. 49 Fitting the side facing panel on the right

The side facing panels must be fastened to the roof battens using three clips on each side, right and left (two clips for landscape version).

- ▶ Insert clip (Fig. 50, **Item 1**) into the edge of the side facing panel.
- ▶ Push clip with facing panel towards collector, so that the facing panel is pressed against the collector.
- ▶ Fasten clip with nail provided.

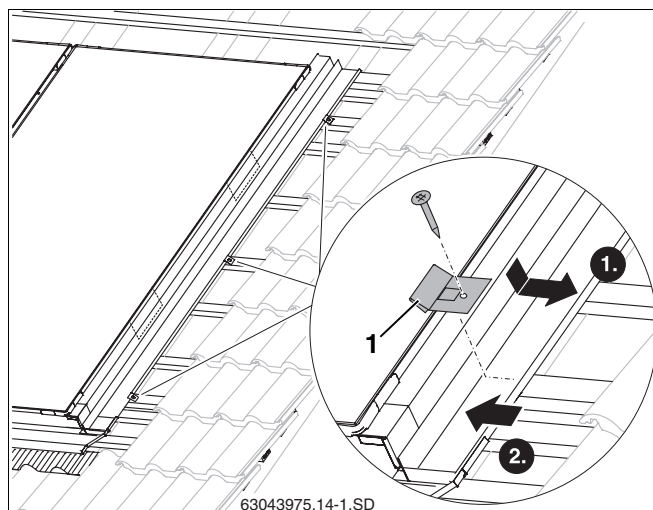

Fig. 50 Securing side facing panel

10.3 Middle cover strip between two collectors

The middle cover strip seals the gap between two collectors.

- ▶ Press cover strip (Fig. 51, **Item 1**) with the folded edge facing downwards into the gap between the two collectors and make sure it is centrally positioned.
- ▶ Using size 8 spanner, tighten screws (Fig. 51, **Item 2**) by hand, beginning at the bottom.

The profile is clamped to the collector frame.

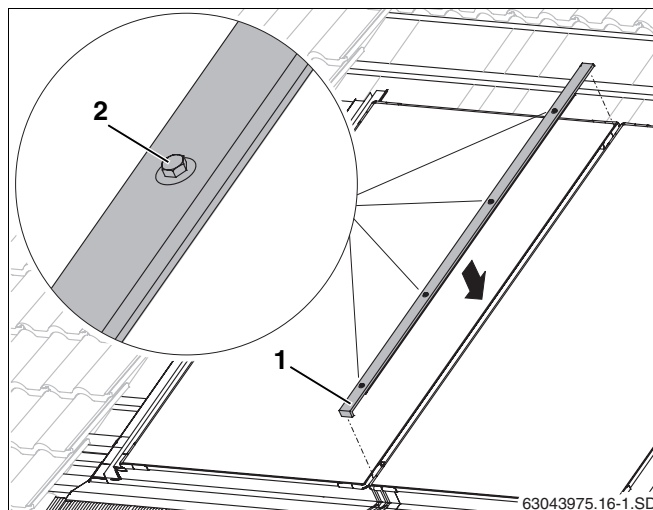

Fig. 51 Middle cover strip

10.4 Middle facing panel (when more than one row is being installed)

The space between two collector arrays is sealed with the middle facing panels.

- ▶ Insert the upward fold on the facing panel (Fig. 52, **Item 2**) into the recessed grip on the collector frame.
- ▶ Feed facing panel (Fig. 52, **Item 1**) towards the collector and into the side facing panel on the right.
- ▶ By applying pressure to the top of the facing panel, it clicks under the recessed channel on the collector frame (Fig. 52, **Item 3**).
- ▶ Place the rubber lip (Fig. 52, **Item 4**) on top of the collector.
- ▶ Remove protective film from the adhesive on the facing panels.



USER NOTE

If fitting more than two collectors, you will need facing panels in the middle (Fig. 53, **Item 1**), between the collector arrays. They must be fitted flush with the collector on their left side (arrow).

For landscape installation, the middle panels must overlap 80–100 mm.

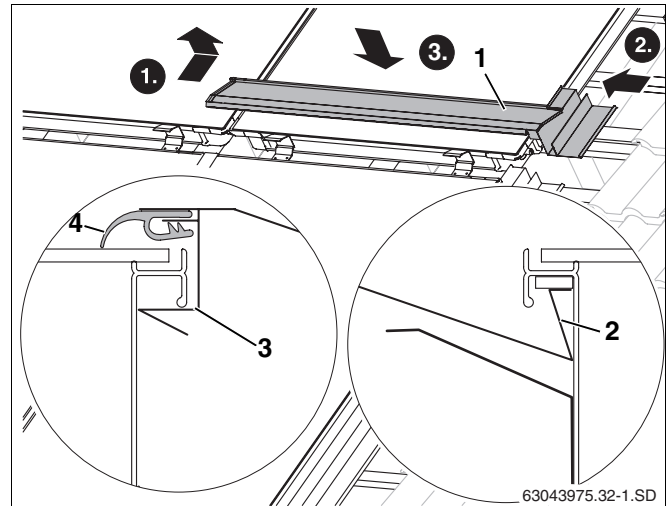

Fig. 52 Inserting first middle facing panel

Item 1: Middle right facing panel

Item 2: Upward fold on the facing panel

Item 3: Anti-slip protection

Item 4: Rubber lip

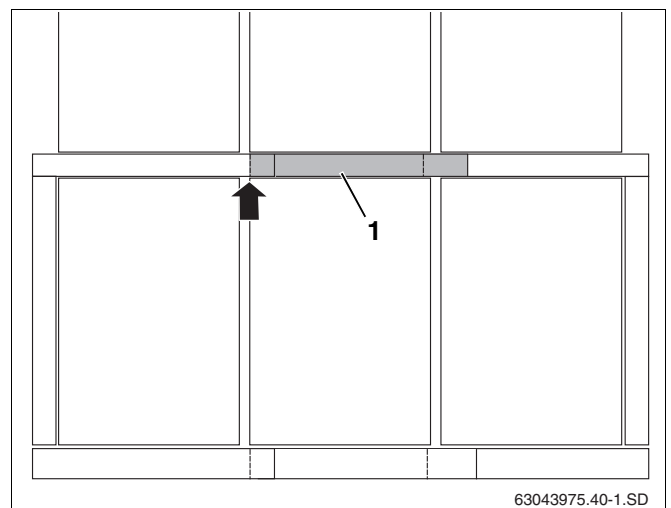

Fig. 53 Positioning the middle facing panels

- ▶ Insert upward fold on the left-hand facing panel (Fig. 54, **Item 1**) into the recessed channel on the collector frame, just as was done with the right-hand facing panel.
- ▶ Feed facing panel towards the collector and into the side facing panel on the left.
- ▶ By applying pressure to the top of the facing panel, it clicks under the recessed channel on the collector frame (Fig. 52, **Item 3**).
- ▶ Shorten the rubber lip (Fig. 54, **Item 3**), so that it touches the rubber lip on the right-hand facing panel.
- ▶ Place rubber lip on the left-hand facing panel onto the fold on the right-hand facing panel (Fig. 54, **Item 2**).
- ▶ Press the upper facing panel down onto the lower one.

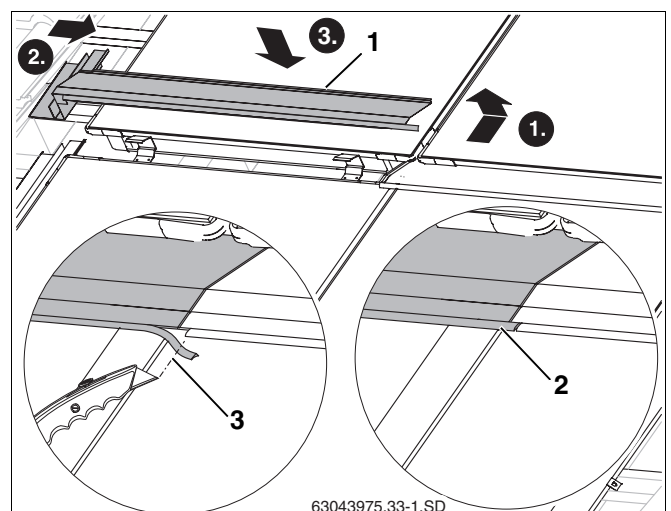

Fig. 54 Laying middle-left facing panel in place

10.5 Side facing panels on the upper row (if installing more than one row)

- ▶ Fit the upper side facing panels (Fig. 55, **Item 1**) in the same way as the lower ones (Chapter 10.2 "Side facing panels").



BUILDING DAMAGE

from leaks in the roof.

CAUTION!

- ▶ Push the side facing panels over the panel fold in the middle panels (Fig. 55, **Item 2**).

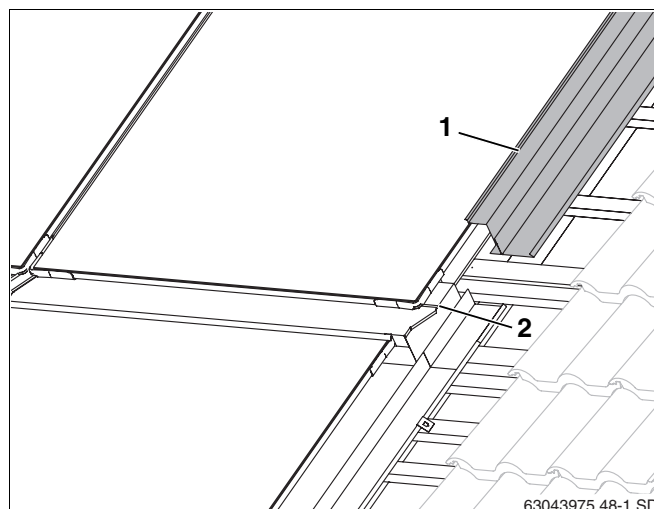

Fig. 55 Upper right facing panel

10.6 Upper facing panels

Begin on the right when fitting the upper facing panels.

- ▶ Feed the upper right facing panel (Fig. 56, **Item 1**) into the side facing panel on the right.
- ▶ By applying pressure to the top of the facing panel, it clicks under the recessed channel on the collector frame (Fig. 56, **Item 3**).
- ▶ Place the rubber lip (Fig. 56, **Item 2**) on top of the collector.

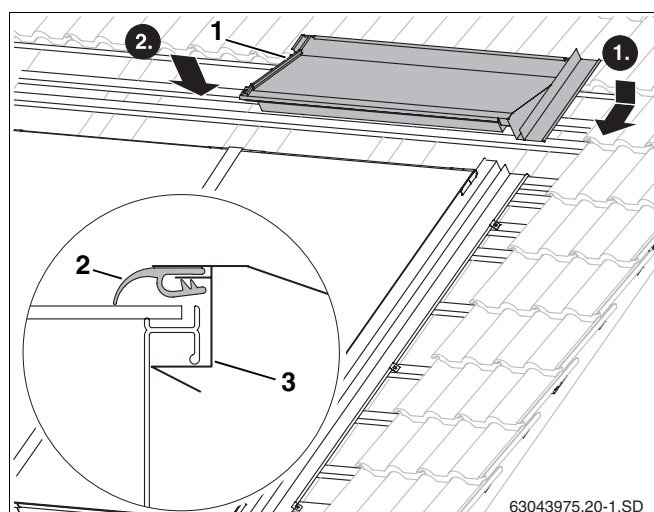

Fig. 56 Upper right facing panel

- ▶ Feed panel fold on remaining upper facing panels (Fig. 57, **Item 2**) into the fitted facing panel and then push towards the collector.
- ▶ Feed the upper left facing panel (Fig. 57, **Item 1**) into the side facing panel on the left.
- ▶ By applying pressure to the top of the facing panel, it clicks under the recessed channel on the collector frame (Fig. 56, **Item 3**).

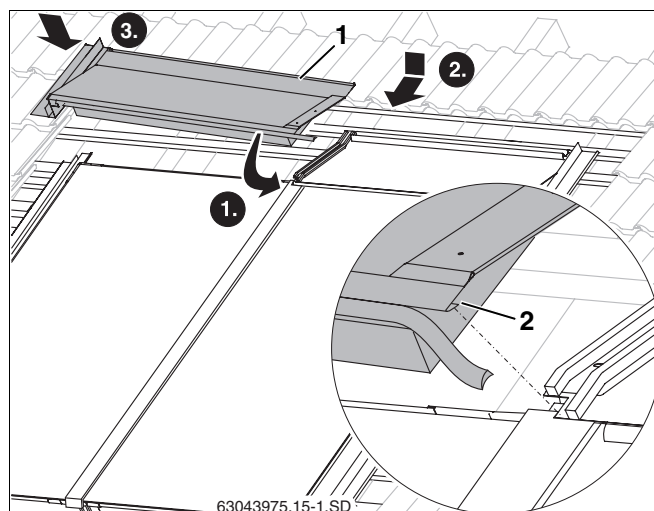

Fig. 57 Upper left facing panel

- ▶ Shorten the rubber lip (Fig. 58, **Item 2**), so that it touches the rubber lip on the right-hand facing panel.
- ▶ Place rubber lip on the left-hand facing panel onto the fold on the right-hand facing panel. (Fig. 58, **Item 1**).

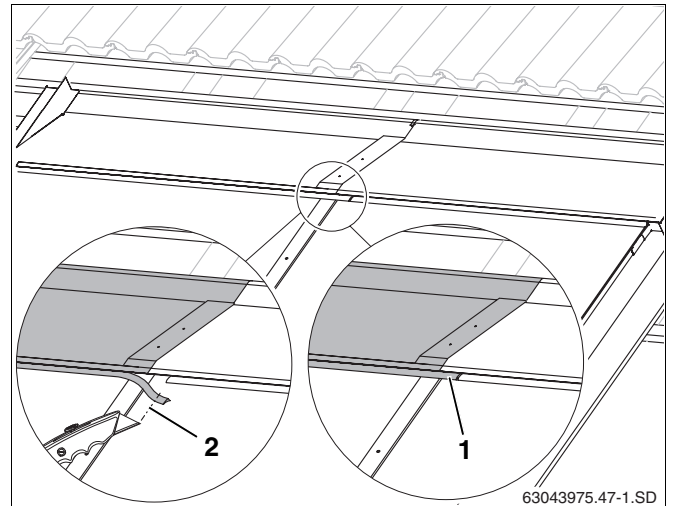

Fig. 58 Upper left facing panel

- ▶ Fasten each panel overlap with two 25 mm long plumbing screws (Fig. 59, **Item 1**) (provided).

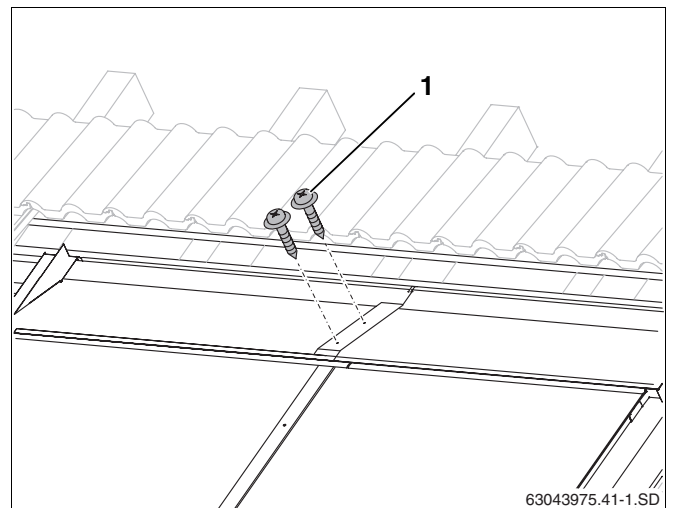

Fig. 59 Joining upper facing panels with screws

Each upper facing panel must be fastened to the roof battens with two clips. In addition, each outer facing panel must be fixed in place with one clip.

- ▶ Insert clip (Fig. 60, **Item 1**) into the edge of the facing panel.
- ▶ Push clip with facing panel towards collector, so that the facing panel is pressed against the collector.
- ▶ Fasten clip with nail provided.

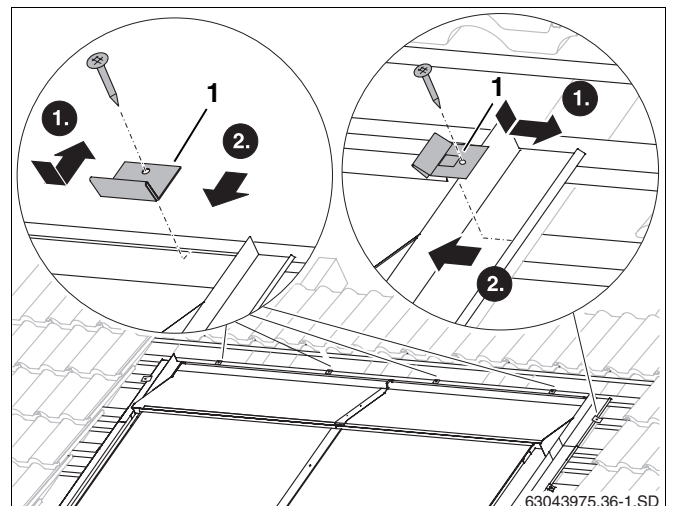

Fig. 60 Fastening upper facing panels with clips

10.7 Covering the roof



USER NOTE

Fasten cut pan tiles with suitable brackets if necessary (available from a roofing specialist).



CAUTION!

BUILDING DAMAGE

from roof leaks if pan tiles are not placed far enough over the facing panels.

10.7.1 Upper pan tiles

- ▶ Place one whole pan tile on top of the upper facing panel.
- ▶ Cut the pan tile so that:
 - it covers the facing panel (Fig. 61, **Item 2**) as much as possible, but does not come into contact with it, and
 - the cut pan tile is lying at the same angle as the uncut pan tiles (this ensures that the pan tile cross-section is continuous and regular). You can adjust the angle using the pan tile overlay.
- ▶ Place the pan tile overlay (Fig. 61, **Item 1**) according to the calculated position and fasten to the roof batten.
- ▶ Lay the cut pan tiles (Fig. 61, **Item 3**).

10.7.2 Side pan tiles

- ▶ Cut pan tiles to dim. X (Table 5, Page 16) and lay.

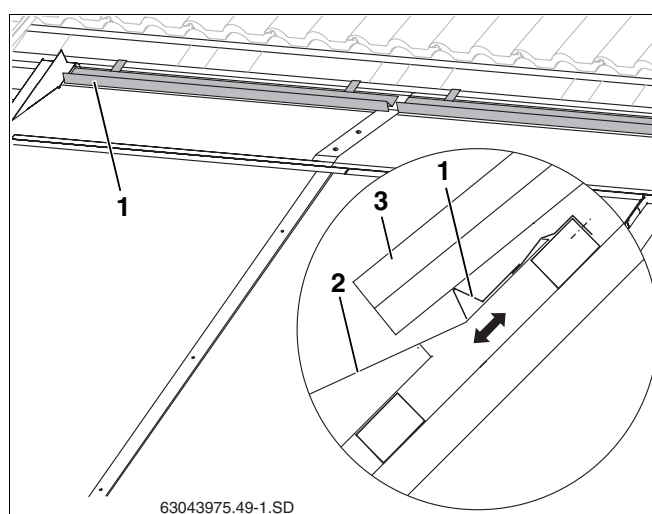

Fig. 61 Laying and securing the pan tile overlay

Item 1: Pan tile overlay

Item 2: Cut pan tile

Item 3: Upper facing panel

11 Final activities



USER NOTE

If you are venting the solar heating system with an automatic air vent valve (accessory), you must close the ball valve after the venting procedure (see pump station installation instructions).

11.1 Checking the installation

In addition to the checks on page 33, you must check the following:

- Are all collector and roof cover joints snow and rain proof?

11.2 Insulating the connection and header pipes

Insulation of the manifolds in internal or external installations

- For the insulation of internal pipework, use only high temperature resistant insulating materials.

12 Quick reference guide for two collectors

These instructions are only intended as an overview of the work to be carried out. You **MUST** follow the detailed descriptions for the work on the pages mentioned, and all safety and user instructions.

Roof preparations

1. Mark dim. X and dim. C on the roof. p. 16
2. Installation of anti-slip protection devices p. 18
3. Attach additional roof battens to the roof. p. 18

Preparing to install the collectors

4. Install solar hoses (95 mm) on the right-hand side of the second and all remaining collectors. p. 23
5. Push preassembled dummy plugs onto those connections that are not required and secure using hose clips. p. 23
6. Fit angled nozzles for the long solar hoses. p. 24
7. Insert sealing tape into the recessed channel on the collector frame (at the bottom, and on the outside edges of the collector array). p. 24

Fastening the collectors

8. Let first collector (right) slide into the anti-slip protection devices, 80 mm from the pan tiles. p. 25
9. Push underlay plates under the collector and drill for a screw. p. 25
10. Fasten clamp with screw and washer. p. 25
11. Drill hole for the double-sided clamp on the left collector side (between two collectors). p. 25
12. Push underlay plate under collector and screw in the double-sided clamp a little. p. 25
13. Push second collector with pre-assembled solar hoses towards the first collector and secure using hose clips. p. 26
14. Tighten screws on the double-sided clamp. p. 26
15. Fit one-sided clamps on the left. p. 27

Header connection

16. Insert collector sensor as far as it will go into the collector with the flow line to be connected, and screw tight. p. 28
17. Push long solar hoses onto angled nozzles and fix in place with hose clips. p. 29
18. Insert compression fittings into solar hoses and secure with hose clips. p. 29
19. Feed solar hose together with the sensor cable through the roof. p. 29
20. Perform installation checks. p. 33

Installing the facing panel

21. Insert lower facing panels from right to left and fasten with plumbing screws. p. 34
22. Insert side panels and fix in place with clips. p. 36
23. Latch cover strip between collectors and tighten screws by hand. p. 36
24. Insert upper facing panels from right to left, cut rubber lip and push into right-hand facing panel. p. 38
25. Fasten upper facing panels with clips and fix to the overlaps with plumbing screws. p. 39
26. Fit pan tile overlay and cut pan tiles to size. p. 40

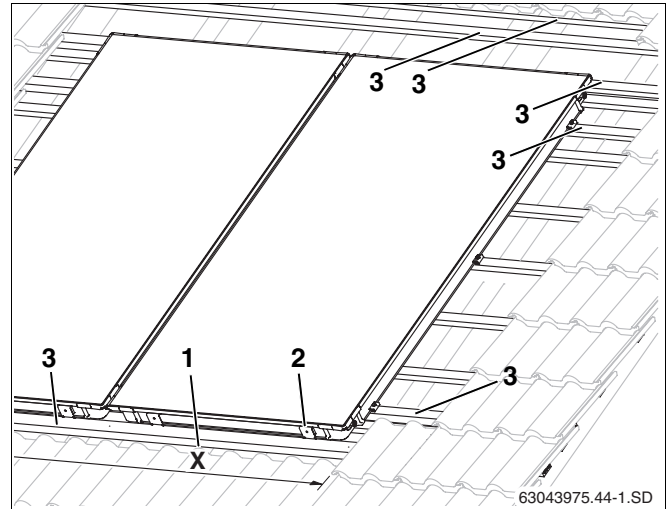

Fig. 62 Roof preparations

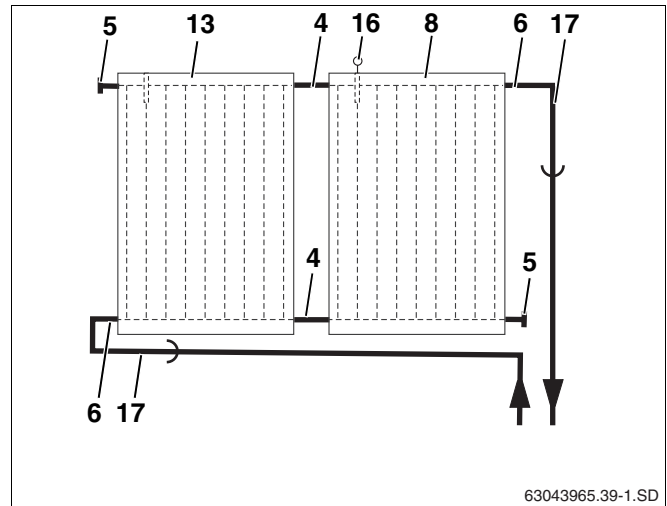

Fig. 63 Pipework connections

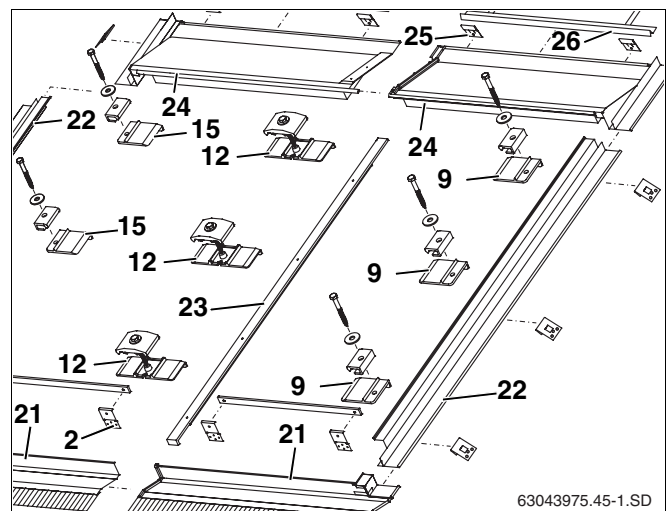

Fig. 64 Fastening and covering two collectors

EXCELLENCE COMES AS STANDARD

Worcester, Bosch Group

Cotswold Way, Warndon, Worcester WR4 9SW.

Tel. 01905 754624 Fax. 01905 754619

Worcester, Bosch Group is a brand name of BBT

Thermotechnology UK Ltd.

www.worcester-bosch.co.uk

6 720 613 054a (2006/04)

CONTACT INFORMATION

WORCESTER, BOSCH GROUP:

TECHNICAL: 08705 266241

SERVICE: 08457 256206

SPARES: 01905 752571

LITERATURE: 01905 752556

TRAINING: 01905 752526

SALES: 01905 752640

WEBSITE: www.worcester-bosch.co.uk



WORCESTER
Bosch Group